

Oktarina Heriyani - Performance Improvement of a Forced Draught Cooling Tower Using a Vortex Generator

by Oktarina Heriyani Uploaded By Lutfan Zulwaqar

Submission date: 05-Apr-2023 11:50AM (UTC+0700)

Submission ID: 2056334382

File name: 30_1005-Manuscript_with_authors_details-16625-1-10-20210306.pdf (1.12M)

Word count: 4520

Character count: 23287



Performance Improvement of a Forced Draught Cooling Tower Using a Vortex Generator

Dan Mugisidi^{1,*}, Oktarina Heriyani², Pancatavta Hesti Gunawan¹, Dwi Apriani¹

¹ Department of Mechanical Engineering, Universitas Muhammadiyah Prof. Dr HAMKA, Jakarta, Indonesia

² Department of Electrical Engineering, Universitas Muhammadiyah Prof. Dr HAMKA, Jakarta, Indonesia

ARTICLE INFO

Article history:

Received 22 November 2020

Received in revised form 16 January 2021

Accepted 23 January 2021

Available online 30 January 2021

ABSTRACT

Cooling systems using colling towers are often an important element in a production process and always involve water or energy consumption. Therefore, increas²² the efficiency of the colling tower will reduce water and / or energy consumption. In order to increase the efficiency of colling tower energy consumption, the most studied part is the fills, where heat transfer occurs. However, there³⁵ no studies on the use of vortex generators in colling tower fills. Hence the aim of this study was to evaluate the performance improvement in a forced draught cooling tower using a vortex generator. It was conducted on a laboratory scale using single fill as a trial medium. The fill was made of 3-mm acrylic with dimensions of 30 × 30 × 1950 mm. A three-unit vortex generator was placed inside the fill. The rectangular vortex generator was made of 0.5-mm thick aluminium and had a size of 50 × 10 mm. Data were retrieved for²⁵ fills with and without a vortex generator. Water and air discharge of 1 L/minute and an inlet water temperature of 60°C were maintained. The results indicated that the effectiveness of the fill with a vortex generator was increased by 90.72% compared to the fill without a vortex generator.

Keywords:

Cooling tower; Forced draft; Vortex generator; CFD Simulation

16

1. Introduction

Cooling systems play an important role in maintaining the temperature of production machinery so that it can work optimally. Optimization of a cooling system can reduce water and energy consumption [1]. An example of a cooling system²⁰ is a cooling tower, which is a heat exchanger for reducing water temperature using air flow. One type of cooling tower is the forced draught cooling tower.

Forced draught cooling towers are used in various industries because of their high air resistance, relatively quiet fans and lower power consumption, even though their cooling efficiency is lower than that of induced draught cooling towers [2,3].

* Corresponding author.

E-mail address: dan.mugisidi@uhamka.ac.id (Dan Mugisidi)

<https://doi.org/10.37934/cfdl.13.1.4557>

Several studies have been conducted to improve the efficiency of cooling towers. Improvement of evaporation can reduce the wet ball by 85–95%, while the filler surface affects the decrease in the ratio of water mass flux to air [4,5]. Interesting results have been obtained using a fill made alternative material such as pebbles, PET strip, and coconut husk and energy losses also reduced using alternative fill [6,7]. Gao *et al.*, [8] demonstrated that wind speed affects efficiency and temperature decrease. Ramakrishnan and Arumugam [9] examined the optimization of operating parameters and conducted a performance evaluation of forced draught cooling towers using the response surface methodology (RSM) and artificial neural network (ANN) methods. The results indicated that a lower water temperature was obtained with the ANN model than with RSM. Johannes [10] used water and air fluid distribution and found that a lower water/air mass flow rate ratio caused a decrease in efficiency. Murugaveni and Shameer [11] investigated the performance of a forced draught cooling tower using Ansys Fluent Software, varying the parameters of the air inlet with different air inlet angles and installing nozzles in the air inlet to increase the effectiveness of the cooling tower model. Wang *et al.*, [12] reported a decrease in cooling performance in the presence of a crosswind. A study that aimed to improve the performance of cooling towers with air vortex distribution of the crosswind found that the distribution of air within a vortex, when the wind blew on the cooling tower, caused a disruption of heat transfer and mass, thereby reducing performance [13]. Although various methods and materials have been used to improve cooling tower performance, no studies have explored vortex generators inside the fill in a cooling tower to increase heat transfer and the tower's efficiency. In fact, heat transfer can be increased by adding a vortex generator [14], which causes flow instability (turbulence) and the development of boundary layers and vortices [15]. The vortices themselves are affected by an increase in the Re number and the height of the vortex generator [16,17]. An inline winglet vortex arrangement results in the greatest heat transfer and fluid mixing with increases in heat transfer by 36.23%, in the friction factor by 36.29% and in thermal performance by 28.5% [18]. This study aimed to use a vortex generator to increase the efficiency of a forced draught cooling tower.

2. Methodology

This study used a fill in a cooling tower. Convection heat transfer from water to cooling air occurs in every single fill separately. The fill is located in a vertical canal that is passed through by hot water from the water intake to the water tank. At the same time, cold air is taken in by the fan so that it flows from the air intake to the fan through the fill, as shown in the cooling tower scheme in Figure 1, and hot water meets the cooling air flowing in the opposite direction inside the fill. Then, to study the effect of vortex generators on cooling tower performance, this study only uses one fill as a model.

The experimental rig was based on Ramakrishnan and Arumugam's [9] test model, with a cross-sectional area of 90,000 mm². The size of each fill was 30 × 30 mm with a height of 1,950 mm. Since this study aimed to evaluate the effect of installing a vortex generator in a fill, we compared only a single fill with a vortex generator (VG) and a fill without a vortex generator (NVG). The fill was covered with an insulator so that it was not affected by ambient temperature. The amount of water and air entering the fill was 1 L/minute [9]. Water from the basin was pumped to the storage. The water contained in the storage was heated using a heater to maintain a temperature of 60°C and then flowed into the fill through a sprinkler to break the water into small beads. Excess water in the storage was channelled back to the water tank. At the same time, air from the compressor was channelled through pipes to the bottom of the fill. The water and air discharge were regulated using a manually operated valve. The thermocouple for the inlet water was positioned below the sprinkler, while the thermocouple for the exit air was placed above the sprinkler. At the bottom of the fill, the

temperature of exiting water was measured below the inlet air duct, while the inlet air temperature gauge was placed above the duct, as illustrated in Figure 2.

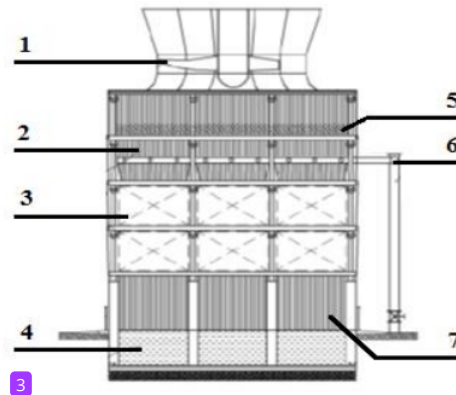

Fig. 1. Schematic of the forced draught cooling tower [2]. 1: Fan, 2: Wall, 3: Fill, 4: Water tank, 5: Drift eliminator, 6: Water intake, 7: Air intake

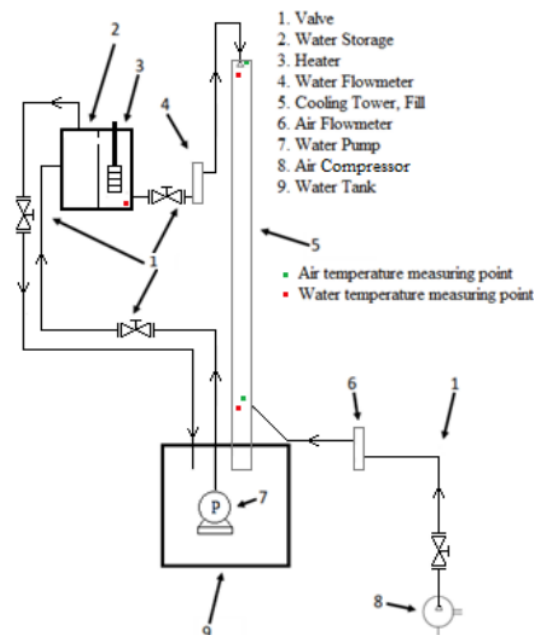

Fig. 2. Schematic of the experimental rig

The height of VG affects the intensity of the vortices because if the VG is higher, the intensity of the resulting vortex increases because the cross-sectional area of the flow decreases, causing an increase in flow velocity [19]. Based on the results of Han's [20] research, the best vortex generator height compared to the channel height or the VG height ratio is up to 0.47. This study using aluminium rectangular wing vortex generator with a size of $50 \times 10 \times 0.5$ mm with a height ratio 0.33, as shown in Figure 3. The distance between vortex generator inside the rectangular channel

can be determined by using the ratio of the distance of the vortex generator inside the channel to the length of the channel, also referred as to the longitudinal pitch ratio. The longitudinal pitch ratio of 0.18 produces the largest vortices, while the longitudinal pitch ratio above 0.24 to 0.36 is constant and can affect heat transfer in the channel because induced vortices that form previously can combine with subsequent VG vortices [20,21]. Therefore, in this study, taking into account the length of the fill, the longitudinal pitch ratio used is 0.19 which is obtained from the distance between vortex generator (D) of 375 mm to the channel length (L) of 1950 mm. Another parameter that greatly affects the vortex generator is the angle of attack. The angle of attack of VG is a very important parameter for increasing heat transfer because the intensity of vortices and fluid mixing depends on the angle of attack [22-24]. The angle of attack in this study refers to Lu and Zhai [25] who stated that the angle of attack 15° has the best hydraulic thermal performance.

The temperature data were collected using a Fluke 51 digital thermometer with a type K thermocouple with a 0.05% and 0.3°C accuracy. Data collection was performed every 15 minutes from 14:45 to 16:30 for was performed over six days, not sequentially, taking ambient temperature into consideration. VG and NVG data were retrieved for three days (VG1, VG2 and VG3, and NVG1, NVG2 and NVG3, respectively).

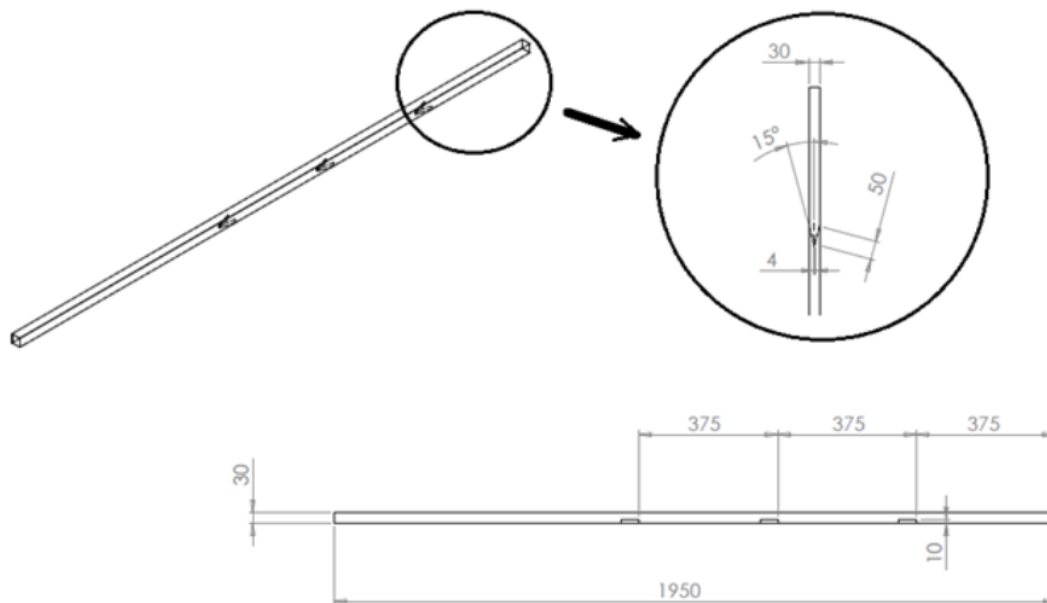

Fig. 3. Arrangement of the vortex generator inside the fill

2.1 Performance Parameters

2.1.1 Range

By determining the entry and exit properties of the air and water, range (R_{CT}), the simplest method of examining the performance of the cooling tower, where T_{wi} is the temperature of the water entering the fill, and T_{wo} is the temperature of the water leaving the fill [26].

$$R_{CT} = T_{wi} - T_{wo} \quad (1)$$

2.1.2 Approach

Approach (A_{CT}) is the difference between the air wet-bulb temperature and the water temperature, where T_{wo} is the water temperature at exit, and T_{wb} is the wet-bulb temperature.

$$A_{CT} = T_{wo} \text{ (}^\circ\text{C)} - T_{wb} \text{ (}^\circ\text{C)} \quad (2)$$

2.1.3 Merkel Number

The Merkel number (M_e) involves two phenomena in a cooling tower, sensible heat transfer and evaporative heat transfer, and is defined as follows [27,28]:

$$M_e = \frac{\alpha_a F T}{C_{pa} M_a} \quad (3)$$

M_e is calculated using the simple logarithmic mean enthalpy difference (LMED) method as follows:

$$M_e = \frac{h_{a,o} - h_{a,i}}{\Delta h_m} \quad (4)$$

$$\Delta h_m = \frac{(h_{a,wi} - h_{a,o}) - (h_{a,wo} - h_{a,i})}{\ln \frac{h_{a,wi} - h_{a,o}}{h_{a,wo} - h_{a,i}}}, \quad (5)$$

where Δh_m is the LMED.

2.1.4 Effectiveness

Effectiveness is estimated by comparing the range of work with its ideal range [29].

$$e_{CT} = \frac{T_{wi} - T_{wo}}{T_{wi} - T_{wb}} \times 100\% \quad (6)$$

2.1.5 CFD Simulation

Computational fluid dynamics (CFD) modelling was performed before the study was conducted to predict vortices on the vortex generator using Ansys Fluent 18.2 software. The computation settings and meshing of the CFD simulation are shown in Table 1 and Figure 4, respectively. The default parameters were used for other settings.

Table 1
Computation settings

No.	Setting	Parameter
1	Gravity	9.81
2	Multiphase	Eulerian
3	Turbulent	RNG. K-epsilon
4	Energy	On

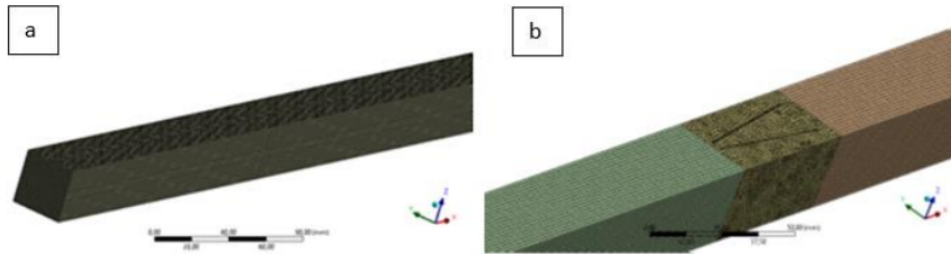

Fig. 4. Meshing of the CFD simulation of a fill (a) without and (b) with a vortex generator

The computational domain in Figure 4(a) is divided into a set of hexahedral cells to achieve high, convergent resolution. However, the division of the computational domain in Figure 4(b) uses tetrahedra cells because they cannot achieve high convergence and resolution. Furthermore, the number of mesh is determined using the grid independency test.

Grid independency test is used to varying the number of elements and further accuracy of simulation [30]. This test is carried out to obtain the minimum number of meshes that can provide consistent, repeatable, and low error results. Table 2. shows the grid independency test with the number of mesh elements from 300,000 to 1,000,000. The parameter used to see changes in the simulation results is the average velocity of water in the area after the first vortex generator. The results show that the number of meshes to the water velocity does not show a significant change with each deviation below 10%. Considering the results and calculation time, a mesh with an element size of 1.5 was chosen as the parameter used in the simulation.

Table 2
Grid Independency Test

Element Size (mm)	Number of Element	Node number	Water Velocity (m/s)	Deviation
2	327.821	262.307	-2,43162	-
1,8	439.020	352.376	-2,30936	-5,0279238
1,6	594.586	484.769	-2,19683	-4,8727786
1,55	638.473	517.565	-2,14458	-2,3784271
1,5	702.614	569.901	-2,12903	-0,7250837
1,4	849.013	688.432	-1,95753	-8,0553116
1,3	1.070.306	875.732	-1,81828	-7,1135564

3. Results

3.1 Experimental Result

This experiment was performed over six days, not sequentially, to take ambient temperature into account. The collected data were in an environment temperature range of 33.1–33.6°C.

Figure 5 shows a comparison of the ranges obtained on three days. The average temperature range for the fill with the VG was 6.08–6.1°C, while the NGV fill had an average range of 3.4–3.9°C. This indicates that the VG resulted in a greater temperature decrease than the NVG. Since the range can be understood as the transfer of energy from water to air, the higher value for the range indicates that the cooling tower lowered the temperature more effectively [31,32]. It can therefore be concluded that a VG in the fill can improve water temperature reduction. Moreover, the VG approach had lower values than the NVG, as can be seen in Figure 6.

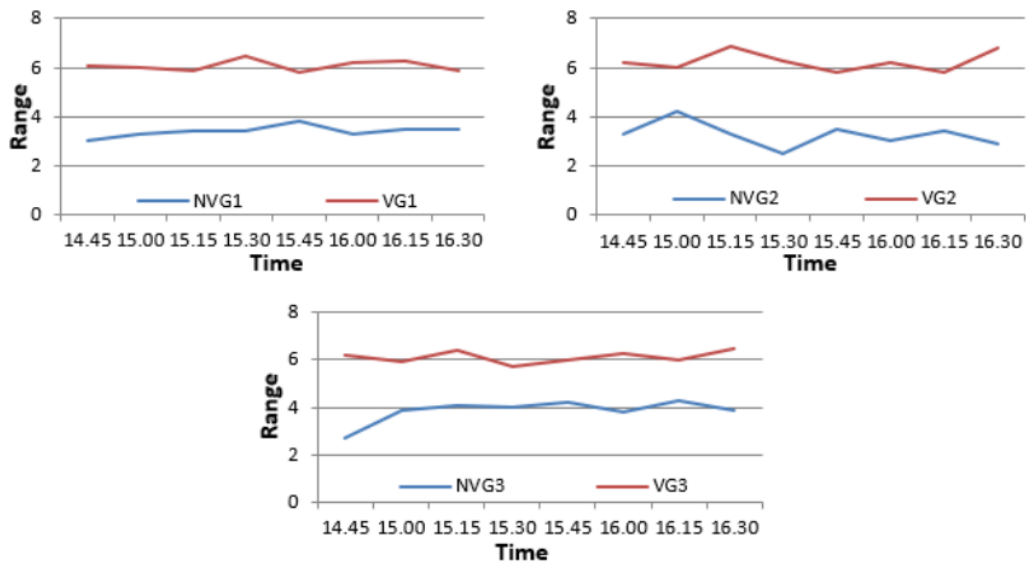

Fig. 5. Temperature ranges without (NVG1 to NVG3) and with a vortex generator (VG1 to VG3) on day 1 to day 3

The performance of the VG fill was closer to ambient temperature. Therefore, the fill with a VG is better than the one without. The lower the approach value, the better the performance of the cooling tower, as it represents its ability to lower the temperature of the water closer to the wet-bulb temperature of the surrounding air [5]. It can thus be concluded that a VG can reduce the approach value in the forced draught fill type of the cooling tower.

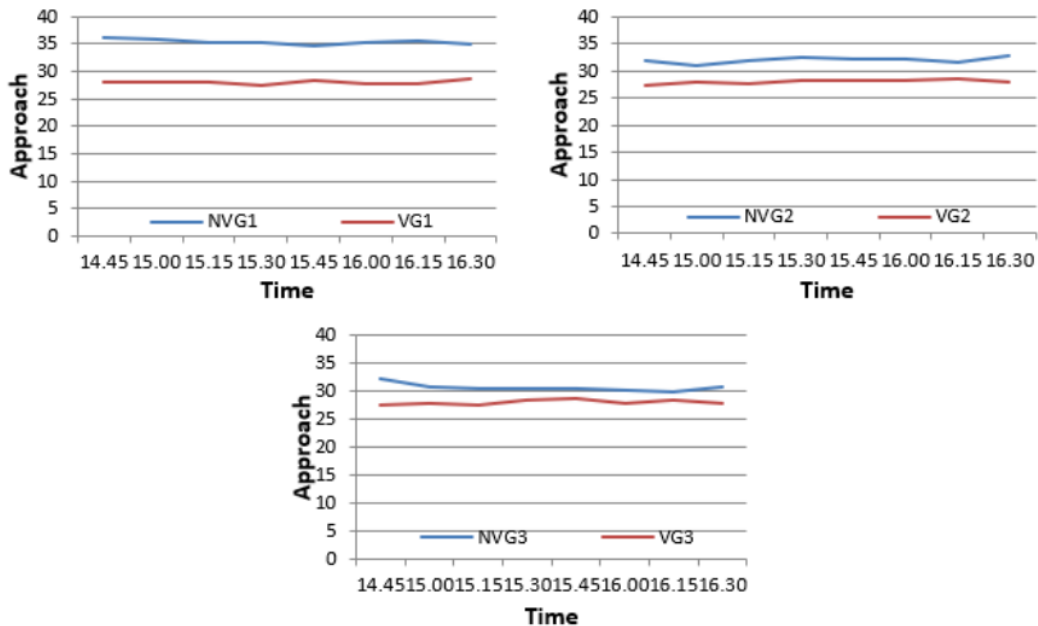

Fig. 6. Cooling tower approach without (NVG1 to NVG3) and with a vortex generator (VG1 to VG3) on day 1 to day 3

Accordingly, as shown in Table 3, the Merkel numbers for the fill with a VG were higher than the those for the fill without one. Disturbances in the flow cause splitting of the fluid into droplets so that the interface surface becomes wider and ultimately increases the transfer of evaporative heat [33].

Table 3
Merkel numbers

Day	NVG	VG
1	1.7397	3.1149
2	1.6694	3.1981
3	1.9764	3.1341

Figure 7 shows that the cooling tower effectiveness (e_{CT}) of the VG was 90% higher than that of the NVG because the vortex generator broke the flow, resulting in greater heat transfer. To visualize the flow, CFD modelling was used (Figure 8).

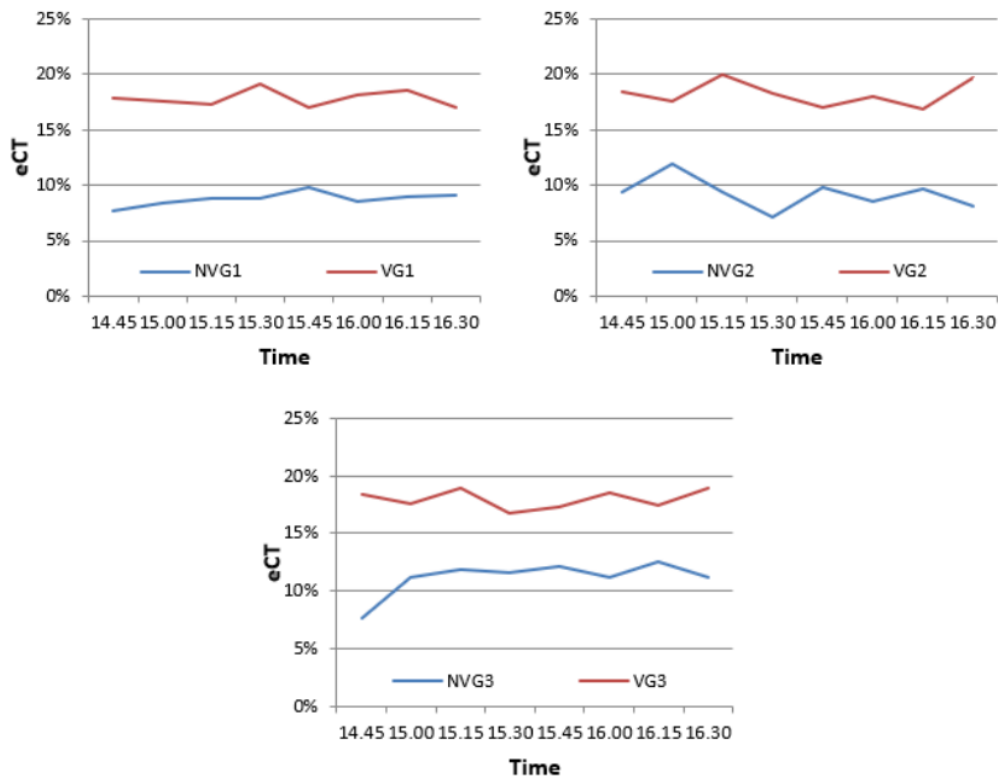

Fig. 7. Cooling tower effectiveness (e_{CT}) without (NVG1 to NVG3) and with a vortex generator (VG1 to VG3) on day 1 to day 3

3.2 CFD Simulation

The results obtained by using the CFD simulation are similar to the experimental results that the vortex generator has the effect of reducing the temperature of the water coming out of the channel. Figure 8 and Figure 9 shows a change in the mixing between water and air after passing through the VG. The mixing of these fluids delays the separation of the boundary layer that forms continuously

the rectangular winglet vortex. The addition of a rectangular winglet-shaped VG controls the boundary layer by mixing high-momentum fluids from the outside into the boundary layer [34]. This is confirmed in Figure 10, which shows the shape of the flow in the area around the VG. A flow deflection formed a vortex in the VG.

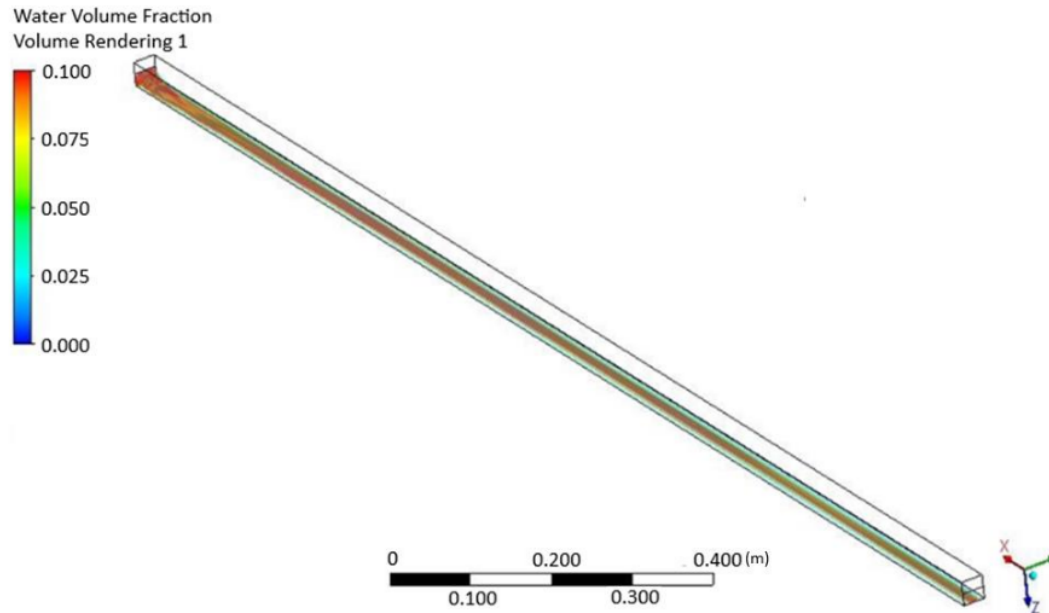

Fig. 8. A CFD 3D model without vortex generator

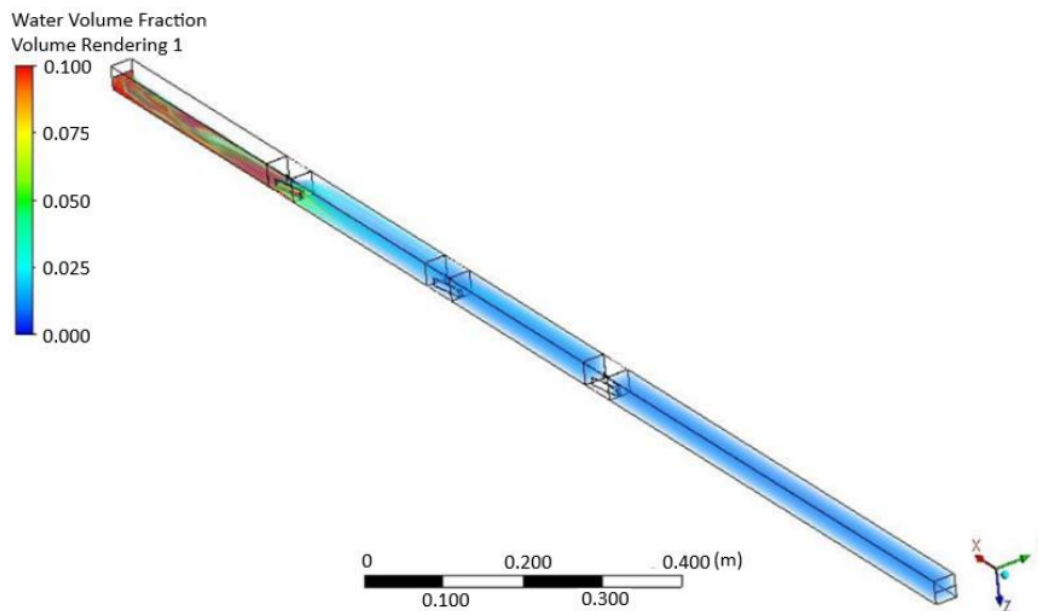

Fig. 9. A CFD 3D model with vortex generators

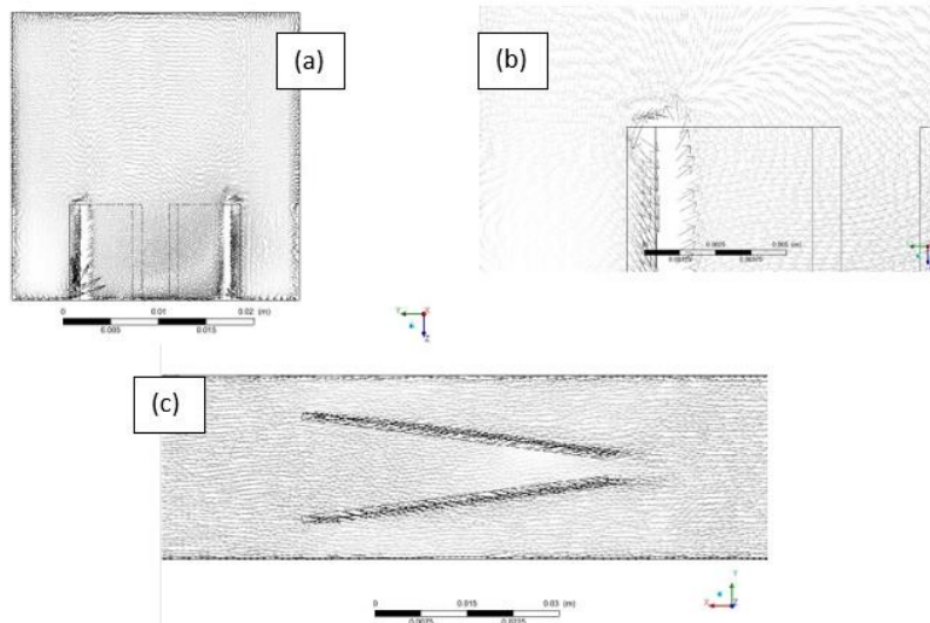

Fig. 10. Vortex generator CFD model: (a) front view, (b) zoom on the vortex generator's tip, and (c) top view

The vortices at the tip of the vortex generator were generated by a separation along its leading edge, resulting in an unstable separate shear layer and curling to its longitudinal vortices, as shown in Figure 10(a) and Figure 10(b). Figure 10(c) shows the vortices generated along the vortex generator. As the pressure difference between the upstream and downstream sides creates a split of flow along the edge of the vortex generator, longitudinal vortices are generated [35]. Furthermore, the obtained Re number with a vortex generator was greater than without a vortex generator for both air and water. Without a vortex generator, the Re number was 41.54 for air and 172,041 for water, while with the addition of a vortex generator, it was 57.62 for air and 286,735 for water. A higher Reynolds number creates counter rotating vortices for various distances of rectangular winglets in vortex formation [36].

4. Conclusions

This study compared a fill with a vortex generator (VG) with a fill without a vortex generator (NVG). The results indicate that the VG increased the performance of the fill. Cooling tower parameters were used to measure the increase in fill performance. The temperature range of the VG was wider than that of the NVG, whereas the approach value of the VG was lower than that of the NVG. The effectiveness of the VG was 90% higher than that of the NVG. This study demonstrates that a VG can improve the performance of a fill in a cooling tower. Therefore, it is necessary to research the application of vortex generators in a cooling tower system to increase its efficiency.

Acknowledgement

This research was funded by a grant from Universitas Muhammadiyah Prof. Dr HAMKA (734/F.03.07/2019) and supported by the Office of Research and Development of Universitas Muhammadiyah Prof. Dr HAMKA.

References

- [1] Goshayshi, H. R., J. F. Missenden, and R. Tozer. "Cooling tower-an energy conservation resource." *Applied Thermal Engineering* 19, no. 11 (1999): 1223-1235.
[https://doi.org/10.1016/S1359-4311\(98\)00119-7](https://doi.org/10.1016/S1359-4311(98)00119-7)
- [2] Brin, A. A., and A. I. Petruchik. "Thermal Efficiency of Forced Draft Cooling Tower With Full Cone Nozzles." *CYSENI 2011* (2011).
- [3] Putra, Raden Suhardi. "Analisa perhitungan beban cooling tower pada fluida di mesin injeksi plastik." *Jurnal Teknik Mesin Mercu Buana* 4, no. 2 (2015): 56-62.
<https://doi.org/10.22441/jtm.v4i2.1010>
- [4] Pearlmutter, D., E. Erell, Y. Etzion, I. A. Meir, and H. Di. "Refining the use of evaporation in an experimental down-draft cool tower." *Energy and Buildings* 23, no. 3 (1996): 191-197.
[https://doi.org/10.1016/0378-7788\(95\)00944-2](https://doi.org/10.1016/0378-7788(95)00944-2)
- [5] Mansour, M. Khamis, and M. A. Hassab. "Innovative correlation for calculating thermal performance of counterflow wet-cooling tower." *Energy* 74 (2014): 855-862.
<https://doi.org/10.1016/j.energy.2014.07.059>
- [6] Tomás, A. C. C., S. D. O. Araujo, Marcos D. Paes, Ana RM Primo, J. A. P. Da Costa, and A. A. V. Ochoa. "Experimental analysis of the performance of new alternative materials for cooling tower fill." *Applied Thermal Engineering* 144 (2018): 444-456.
<https://doi.org/10.1016/j.applthermaleng.2018.08.076>
- [7] Afanasenko, V. G., P. A. Kulakov, Yu L. Galimova, and D. I. Sidorkin. "Modeling of heat and mass transfer processes in cooling towers and structure optimizing of polymer filler." In *IOP Conference Series: Materials Science and Engineering*, vol. 709, no. 4, p. 044017. IOP Publishing, 2020.
<https://doi.org/10.1088/1757-899X/709/4/044017>
- [8] Gao, Ming, Feng-Zhong Sun, Kai Wang, Yue-tao Shi, and Yuan-bin Zhao. "Experimental research of heat transfer performance on natural draft counter flow wet cooling tower under cross-wind conditions." *International Journal of Thermal Sciences* 47, no. 7 (2008): 935-941.
<https://doi.org/10.1016/j.ijthermalsci.2007.07.010>
- [9] Ramakrishnan, Ramkumar, and Ragupathy Arumugam. "Optimization of operating parameters and performance evaluation of forced draft cooling tower using response surface methodology (RSM) and artificial neural network (ANN)." *Journal of Mechanical Science and Technology* 26, no. 5 (2012): 1643-1650.
<https://doi.org/10.1007/s12206-012-0323-9>
- [10] Johanes, Susanto. "Komparasi karakteristik menara pendingin menggunakan beberapa tipe susunan pipa-pipa sebagai pendistribusi cairan." In *Forum Teknik*, vol. 34, no. 1. (2011): 67-75.
- [11] Murugaveni, S. Parimala, and P. Mohamed Shameer. "Analysis of forced draft cooling tower performance using Ansys Fluent software." *International Journal of Research in Engineering and Technology* 4, no. 4 (2015): 217-229.
<https://doi.org/10.15623/ijret.2015.0404039>
- [12] Wang, Weiliang, Hai Zhang, Pei Liu, Zheng Li, Junfu Lv, and Weidou Ni. "The cooling performance of a natural draft dry cooling tower under crosswind and an enclosure approach to cooling efficiency enhancement." *Applied Energy* 186 (2017): 336-346.
<https://doi.org/10.1016/j.apenergy.2016.02.007>
- [13] Gao, Ming, Feng-zhong Sun, Ni-ni Wang, and Yuan-bin Zhao. "Experimental research on circumferential inflow air and vortex distribution for wet cooling tower under crosswind conditions." *Applied Thermal Engineering* 64, no. 1-2 (2014): 93-100.
<https://doi.org/10.1016/j.applthermaleng.2013.12.023>
- [14] Yang, Jae Sung, Myunggeun Jeong, Yong Gap Park, and Man Yeong Ha. "Numerical study on the flow and heat transfer characteristics in a dimple cooling channel with a wedge-shaped vortex generator." *International Journal of Heat and Mass Transfer* 136 (2019): 1064-1078.
<https://doi.org/10.1016/j.ijheatmasstransfer.2019.03.072>
- [15] Fiebig, M. "Vortices, generators and heat transfer." *Chemical Engineering Research and Design* 76, no. 2 (1998): 108-123.
<https://doi.org/10.1205/026387698524686>
- [16] Deb, P., G. Biswas, and N. K. Mitra. "Heat transfer and flow structure in laminar and turbulent flows in a rectangular channel with longitudinal vortices." *International Journal of Heat and Mass Transfer* 38, no. 13 (1995): 2427-2444.
[https://doi.org/10.1016/0017-9310\(94\)00357-2](https://doi.org/10.1016/0017-9310(94)00357-2)
- [17] Zaman, K. B. M. Q., D. L. Rigby, and J. D. Heidmann. "Inclined jet in crossflow interacting with a vortex generator." *Journal of Propulsion and Power* 26, no. 5 (2010): 947-954.

- <https://doi.org/10.2514/1.49742>
- [18] Henze, M., and J. Von Wolfersdorf. "Influence of approach flow conditions on heat transfer behind vortex generators." *International Journal of Heat and Mass Transfer* 54, no. 1-3 (2011): 279-287.
<https://doi.org/10.1016/j.ijheatmasstransfer.2010.09.045>
- [19] Md Salleh, Mohd Fahmi, Ahmadali Gholami, and Mazlan A. Wahid. "Numerical evaluation of thermal hydraulic performance in fin-and-tube heat exchangers with various vortex generator geometries arranged in common-flow-down or common-flow-up." *Journal of Heat Transfer* 141, no. 2 (2019).
<https://doi.org/10.1115/1.4041832>
- [20] Han, Zhimin, Zhiming Xu, and Hongwei Qu. "Parametric study of the particulate fouling characteristics of vortex generators in a heat exchanger." *Applied Thermal Engineering* 167 (2020): 114735.
<https://doi.org/10.1016/j.applthermaleng.2019.114735>
- [21] Dietz, C. F., M. Henze, S. O. Neumann, and Jens von Wolfersdorf. "The effects of vortex structures on heat transfer and flow field behind arrays of vortex generators." *Journal of Enhanced Heat Transfer* 16, no. 2 (2009).
<https://doi.org/10.1615/JEnhHeatTransf.v16.i2.60>
- [22] Min, Chunhua, Chengying Qi, Enyu Wang, Liting Tian, and Yaju Qin. "Numerical investigation of turbulent flow and heat transfer in a channel with novel longitudinal vortex generators." *International Journal of Heat and Mass Transfer* 55, no. 23-24 (2012): 7268-7277.
<https://doi.org/10.1016/j.ijheatmasstransfer.2012.07.055>
- [23] Sun, Zhiqiang, Kang Zhang, Wenhao Li, Qiang Chen, and Nianben Zheng. "Investigations of the turbulent thermal-hydraulic performance in circular heat exchanger tubes with multiple rectangular winglet vortex generators." *Applied Thermal Engineering* 168 (2020): 114838.
<https://doi.org/10.1016/j.applthermaleng.2019.114838>
- [24] Biswas, Gautam, Himadri Chattopadhyay, and Anupam Sinha. "Augmentation of heat transfer by creation of streamwise longitudinal vortices using vortex generators." *Heat Transfer Engineering* 33, no. 4-5 (2012): 406-424.
<https://doi.org/10.1080/01457632.2012.614150>
- [25] Lu, Gaofeng, and Xiaoqiang Zhai. "Effects of curved vortex generators on the air-side performance of fin-and-tube heat exchangers." *International Journal of Thermal Sciences* 136 (2019): 509-518.
<https://doi.org/10.1016/j.ijthermalsci.2018.11.009>
- [26] Najjar, Yousef SH. "Forced draft cooling tower performance with diesel power stations." *Heat Transfer Engineering* 9, no. 4 (1988): 36-44.
<https://doi.org/10.1080/01457638808939679>
- [27] Mohiuddin, A. K. M., and K. Kant. "Knowledge base for the systematic design of wet cooling towers. Part I: Selection and tower characteristics." *International Journal of Refrigeration* 19, no. 1 (1996): 43-51.
[https://doi.org/10.1016/0140-7007\(95\)00059-3](https://doi.org/10.1016/0140-7007(95)00059-3)
- [28] Yilmaz, Alper. "Analytical calculation of wet cooling tower performance with large cooling ranges." *Journal of Thermal Science and Technology* 30, no. 2 (2010): 45-56.
- [29] Singh, Kuljeet, and Ranjan Das. "An experimental and multi-objective optimization study of a forced draft cooling tower with different fills." *Energy Conversion and Management* 111 (2016): 417-430.
<https://doi.org/10.1016/j.enconman.2015.12.080>
- [30] Hamad, A., Syed Mohammed Aminuddin Aftab, and Kamarul Arifin Ahmad. "Reducing flow separation in T-junction pipe using vortex generator: CFD study." *Journal of Advanced Research in Fluid Mechanics and Thermal Sciences* 44, no. 1 (2018): 36-46.
- [31] Lemouari, M., M. Boumaza, and I. M. Mujtaba. "Thermal performances investigation of a wet cooling tower." *Applied Thermal Engineering* 27, no. 5-6 (2007): 902-909.
<https://doi.org/10.1016/j.applthermaleng.2006.08.014>
- [32] Indrawati, Titik, Indrariningrum Indrariningrum, and Rhevi Raditya Ginanjar. "Perancangan 'Mini Cooling Tower' Sederhana Sebagai Pendingin Air Kondensor Pada Proses Refluks Ujichemical Oxygen Demand (COD)." *Jurnal Temapela* 1, no. 1 (2018): 16-22.
<https://doi.org/10.25077/temapela.1.1.16-22.2018>
- [33] Singla, Rohit K., Kuljeet Singh, and Ranjan Das. "Tower characteristics correlation and parameter retrieval in wet-cooling tower with expanded wire mesh packing." *Applied Thermal Engineering* 96 (2016): 240-249.
<https://doi.org/10.1016/j.applthermaleng.2015.11.063>
- [34] Schubauer, Galen Brandt, and W. G. Spangenberg. "Forced mixing in boundary layers." *Journal of Fluid Mechanics* 8, no. 1 (1960): 10-32.
<https://doi.org/10.1017/S0022112060000372>
- [35] Fiebig, M., A. Valencia, and Nimai K. Mitra. "Wing-type vortex generators for fin-and-tube heat exchangers." *Experimental Thermal and Fluid Science* 7, no. 4 (1993): 287-295.

-
- [https://doi.org/10.1016/0894-1777\(93\)90052-K](https://doi.org/10.1016/0894-1777(93)90052-K)
- [36] Oyakawa, K., Y. Furukawa, T. Taira, I. Senaha, and T. Nagata. "Effects of vortex generators on heat transfer enhancement in a duct." In *Experimental Heat Transfer, Fluid Mechanics and Thermodynamics* 1993, pp. 633-640. Elsevier, 1993.
- <https://doi.org/10.1016/B978-0-444-81619-1.50075-7>

Oktarina Heriyani - Performance Improvement of a Forced Draught Cooling Tower Using a Vortex Generator

ORIGINALITY REPORT

17%

SIMILARITY INDEX

7%

INTERNET SOURCES

14%

PUBLICATIONS

4%

STUDENT PAPERS

PRIMARY SOURCES

- 1** Oktarina Heriyani, Dan Mugisidi, P H Gunawan, Dwi Apriliana Putri. "The effect of vortex generator on the approach value on forced draft type cooling tower", IOP Conference Series: Materials Science and Engineering, 2020
Publication 2%
- 2** Submitted to UCSI University
Student Paper 1%
- 3** cyseni.com
Internet Source 1%
- 4** A. I. ElSherbini, A. M. Jacobi. "The Thermal-Hydraulic Impact of Delta-Wing Vortex Generators on the Performance of a Plain-Fin-and-Tube Heat Exchanger", HVAC&R Research, 2002
Publication 1%
- 5** Mondal, Pranab Kumar, Sanchayan Mukherjee, Balaram Kundu, and Somchai Wongwises. "Investigation of the crosswind-

influenced thermal performance of a natural draft counterflow cooling tower", International Journal of Heat and Mass Transfer, 2015.

Publication

6

F. Ke, L. B. Wang, L. Hua, S. D. Gao, Y. X. Su. "The Optimum Angle of Attack of Delta Winglet VortexGenerators on Heat Transfer Performance of Finned Flat Tube Bank with Considering Nonuniform Fin Temperature", Experimental Heat Transfer, 2006

Publication

7

cyberleninka.org

Internet Source

8

Zhimin Han, Zhiming Xu, Hongwei Qu. "Parametric study of the particulate fouling characteristics of vortex generators in a heat exchanger", Applied Thermal Engineering, 2020

Publication

9

Reza Javadpour, Saeed Zeinali Heris, Josua P. Meyer. "Experimental study of the effect of filled bed type on the performance of a cross-flow cooling tower with the approach of using nanofluids", Energy Reports, 2022

Publication

10

Submitted to Universiti Teknikal Malaysia Melaka

<1 %

11

Submitted to Heriot-Watt University

Student Paper

<1 %

12

YOUSEF S. H. NAJJAR. "Forced Draft Cooling Tower Performance with Diesel Power Stations", Heat Transfer Engineering, 1988

Publication

<1 %

13

Shantanu Purohit, Madhwesh N, K Vasudeva Karanth, N Yagnesh Sharma. "Heat transfer augmentation using an innovative helicoidal finned absorber plate in a solar air heater - A CFD study", Journal of Solar Energy Engineering, 2018

Publication

<1 %

14

88b13e60-7607-4e97-935f-e791cdded63b.filesusr.com

Internet Source

<1 %

15

www.mdpi.com

Internet Source

<1 %

16

Gao, Ming, Yue-tao Shi, Ni-ni Wang, Yuan-bin Zhao, and Feng-zhong Sun. "Artificial neural network model research on effects of cross-wind to performance parameters of wet cooling tower based on level Froude number", Applied Thermal Engineering, 2013.

Publication

<1 %

17

Submitted to University of Wales Swansea

<1 %

18

theses.hal.science

Internet Source

<1 %

19

www.tib.eu

Internet Source

<1 %

20

A.K.M Mohiuddin, K Kant. "Knowledge base for the systematic design of wet cooling towers. Part I: Selection and tower characteristics", International Journal of Refrigeration, 1996

Publication

<1 %

21

M. Fiebig. "Vortices, Generators and Heat Transfer", Chemical Engineering Research and Design, 1998

Publication

<1 %

22

Wahyu K Sugandi, Kralawi Sita, Totok Herwanto, Shida Habsari. "Energy Analysis on the Processing of Green Tea", Jurnal Teknik Pertanian Lampung (Journal of Agricultural Engineering), 2022

Publication

<1 %

23

Zhou, Wen-Jing, Ju-Fang Fan, Zhi-Geng Wu, Ya-Ling He, and Wen-Quan Tao. "An Efficient Approach for Performance Evaluation and Parameter Design of Heat Transfer Enhancing

<1 %

Structure", 2010 14th International Heat Transfer Conference Volume 4, 2010.

Publication

24

iats17.firat.edu.tr

Internet Source

<1 %

25

www.tandfonline.com

Internet Source

<1 %

26

Duan, Zhiyin, Changhong Zhan, Xingxing Zhang, Mahmud Mustafa, Xudong Zhao, Behrang Alimohammadisagvand, and Ala Hasan. "Indirect evaporative cooling: Past, present and future potentials", Renewable and Sustainable Energy Reviews, 2012.

Publication

<1 %

27

E V Boev, N I Boeva. "Investigation of heat and mass exchange characteristics of packing devices of industrial cooling tower sprinklers", IOP Conference Series: Materials Science and Engineering, 2020

Publication

<1 %

28

Kayvan Abbasi, Aaron P. Wemhoff, Alfonso Ortega. "Detailed and reduced order modeling of steady state counterflow mechanical draft cooling towers for analysis of Data Center energy efficiency", Fourteenth Intersociety Conference on Thermal and Thermomechanical Phenomena in Electronic Systems (ITherm), 2014

<1 %

29

Kim, Min-Hwi, Joon-Young Park, Sang-Woo Ham, and Jae-Weon Jeong. "Energy conservation benefit of water-side free cooling in a liquid desiccant and evaporative cooling-assisted 100% outdoor air system", *Energy and Buildings*, 2015.

Publication

<1 %

30

Prashant Saini, Atul Dhar, Satvasheel Powar. "Performance enhancement of fin and tube heat exchanger employing curved trapezoidal winglet vortex generator with circular punched holes", *International Journal of Heat and Mass Transfer*, 2023

Publication

<1 %

31

Weipeng Deng, Fengzhong Sun, Kun Chen, Xiaoyu Zhang. "The research on plume abatement and water saving of mechanical draft wet cooling tower based on the rectangle module", *International Communications in Heat and Mass Transfer*, 2022

Publication

<1 %

32

Yuanbo Liu, Xuehu Ma, Xuan Ye, Yansong Chen, Yaqi Cheng, Zhong Lan. "Heat transfer enhancement of annular finned tube exchanger using vortex generators: the effect of oriented functional circumferential

<1 %

arrangement", Thermal Science and Engineering Progress, 2018

Publication

33

gcris.iyte.edu.tr

Internet Source

<1 %

34

link.springer.com

Internet Source

<1 %

35

www.akademiabaru.com

Internet Source

<1 %

36

www.iieta.org

Internet Source

<1 %

37

Ahmed, H.E., H.A. Mohammed, and M.Z. Yusoff. "An overview on heat transfer augmentation using vortex generators and nanofluids: Approaches and applications", Renewable and Sustainable Energy Reviews, 2012.

Publication

<1 %

38

T. Surulivelrajan, S. Kathiresan, G. Sathi, B. Narendhiran, M. Selvakumar. "Experimental and numerical analysis of cooling tower efficiency using forced draft", AIP Publishing, 2022

Publication

<1 %

39

M. M. Hemmasian Kashani, K. V. Dobrego. "Heat and mass transfer in natural draft

<1 %

cooling towers", Journal of Engineering
Physics and Thermophysics, 2013

Publication

40

Yen-Tso Chang, Han-Ching Lin, Chi-Jui Huang,
Go-Long Tsai, Jinn-Feng Jiang. "Numerical
Study of Thermal and Flow Characteristics of
Plate-Fin Heat Sink with Longitudinal Vortex
Generator Installed on the Ground",
Mathematical Problems in Engineering, 2014

Publication

<1 %

41

etheses.whiterose.ac.uk

Internet Source

<1 %

Exclude quotes Off

Exclude matches Off

Exclude bibliography On