

PAPER • OPEN ACCESS

## The first proposed of fiber to the home (FTTH) protection unit for clients scattered placement

To cite this article: H Ramza *et al* 2020 *IOP Conf. Ser.: Mater. Sci. Eng.* **821** 012022

View the [article online](#) for updates and enhancements.

You may also like

- [A double-ring Mach-Zehnder interferometer sensor with high sensitivity](#)  
Jing Zhang, Yundong Zhang, Qinghai Song et al.
- [A Highly Settled Disk around Oph163131](#)  
M. Villenave, K. R. Stapelfeldt, G. Duchêne et al.
- [Charge transport optimization in CZT ring-drift detectors](#)  
V Boothman, A Alruhaili, V Perumal et al.



The Electrochemical Society  
Advancing solid state & electrochemical science & technology

### 242nd ECS Meeting

Oct 9 – 13, 2022 • Atlanta, GA, US

Presenting more than 2,400  
technical abstracts in 50 symposia



**ECS Plenary Lecture**  
featuring  
**M. Stanley Whittingham,**  
Binghamton University  
Nobel Laureate –  
2019 Nobel Prize in Chemistry



Register now!



# The first proposed of fiber to the home (FTTH) protection unit for clients scattered placement

H Ramza\*, S A C Aziz, N Z, Mastang, and M S Ab-Rahman

Department of Electrical, Faculty of Engineering, Universitas Muhammadiyah Prof. Dr. Hamka, Jakarta, Indonesia

\*Email: hramza@uhamka.ac.id

**Abstract.** This paper describes the design and analysis of protection schemes that it is not regular customers' location in optical communication system network. Distance and number of customers with the design of optical point protection unit achievements are recognized as the user for a series of rings from CAPU-Ring 1 (Customer Access Protection Unit). CAPU-Ring 1 is made as a safety point of optics that will be placed on the prior user. This system is an optical spot that will be placed in a ring circuit for use in placement of clients scattered. Proposed construction of a series with a protection channel architecture is about designing CAPU-Ring 1 as optical nodes, condition and repair damage to the circuit, the power budget calculations, design in the simulation, and analysis of the node to node. Parameters outlined in this discussion are the relationship of each node optical output power, improving the system of the eye diagram to the distance and also increase the system working against the maximum optical node. Characterization of ring network protection architecture can be identified from the results of a simulation study.

## 1. Overview of CAPU-RING 1

CAPU-Ring 1 (Customer Access Protection Unit) has been designed with 4 channels of alternative safety that will bring optical signal if there is damage to the channel [1-4]. Two main lines proposed FTTH system circuit architecture includes the main channel and the ring channel [5-9]. Both these channels are combined in the form of this CAPU-Ring 1. As shown at Figure1, CAPU-Ring 1 was used for the filamentous placement position that consists of internal component block system proposed [10-12].

Two main switches are put on the both line, such as primary line and ring line. Each linear line (primary line) will work by duplicating with the protection line. Protection channel will be used in case of damage to the active channels at random. Ring channels are also equipped with two optical channels for each node is an active channel and channel protection will be running in the event of damage to the active channel. Then the optical signal will have four alternative will be chosen to carry the optical signals to each receiver.

The decrement signals will pass through the main switch on the linear channel (primary line) and it will pass through an optical splitter, to distribute power to multiple recipients. Hence under normal conditions without damage, the optical signal goes through an active channel, but if there is damage to the active channel protection channel will be activated. Then, the signal enters the optical coupling, and here the signal is divided according to percentage of power around 1-n% for the signal



transmission component and the n% of the signal dropped. The signal drop is a signal that will be dropped directly to the recipient. Therefore, small-signal power ratio can receive at a receiver only. Input signal is a signal to be transmitted to the output optical node, and the output optical signal node will be input signal the next optical node stage. The drop-signal in the optical coupler have n%-ratio on the linear channel then it will enter to the optical switch (2x1) and also, it will be sent to the receiver via an optical circulator. The linear channel of the Transmitted-Signal will be entering the 2x2- optical switch as an input signal at the next optical node stage.

If two channels work and the protection channel on the linear channel is damaged, then the ring will be activated channels. Initially, the ring line will be through the main multiplexer and then enter an optical coupler then the signal will be divided into two percent of the 1-n% (signal out) and n% (signal drop) as the main channel design. The signal will drop into the 2x1 optical switches and optical-circulator. Transmitted-Signal will enter the 2x2 optical switches and there, an optical switch that is controlled by the ACS (Automatic Control System) will select the channel to be activated. The flow of signals from optical node to the next node (for the ring channels) will be equipped with two-channels multiplexer. In addition, all optical switches that serve to transfer the channel in the optical network will be controlled by ACS.

Following the network protection architecture of CAPU-Ring 1 is developed; there are two lines of terminals TT(1) and TT(2) that are used in the OLT (Optical Line Terminal) for the signal direction decreased as shown in the Figure 1[13]. Each channel of TT(1) and TT(2) are connecting on the linear line and the ring line. In normal status, TT(1) will transmit the signal through a linear decline, while TT(2) is static and it can be disabled and only works when there is damage to the two lines of the linear path.

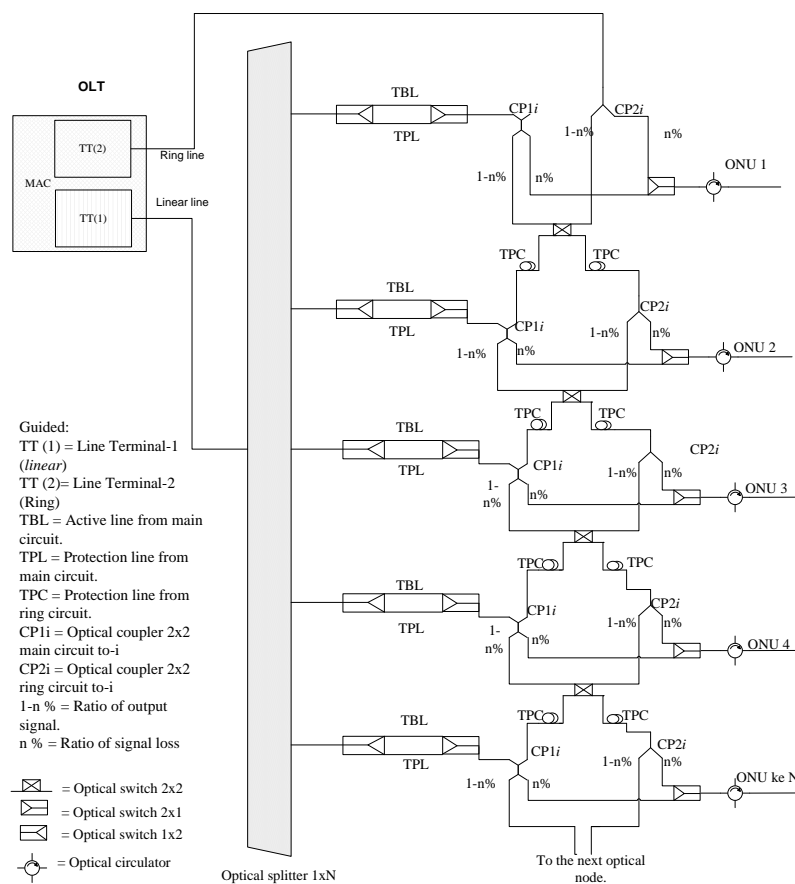

**Figure 1.** CAPU-Ring 1 with linear protection circuit and ring protection circuit.

## 2. Fault condition on the CAPU-RING 1 network

This section describes the classification level of damage to the network security. Four of the fault conditions are identified in the proposed recovery system of this network [14-16]. Fault conditions identified involve two types of protection: linear protection and ring protection. Linear protection is categorized as the protection of the main line and ring protection is a ring network.

### 2.1. Normal conditions (signalling in a linear path)

Normal conditions classified as an optical signal through the line to work in a linear line and after going through an optical coupler, and then the signal will enter the optical circulator that to be sent directly to the recipient. Figure 2 shows the optical signal through the components in the optical node where the line is cut off routes to carry traffic in normal conditions. Then the signal is classified as a signal loss.

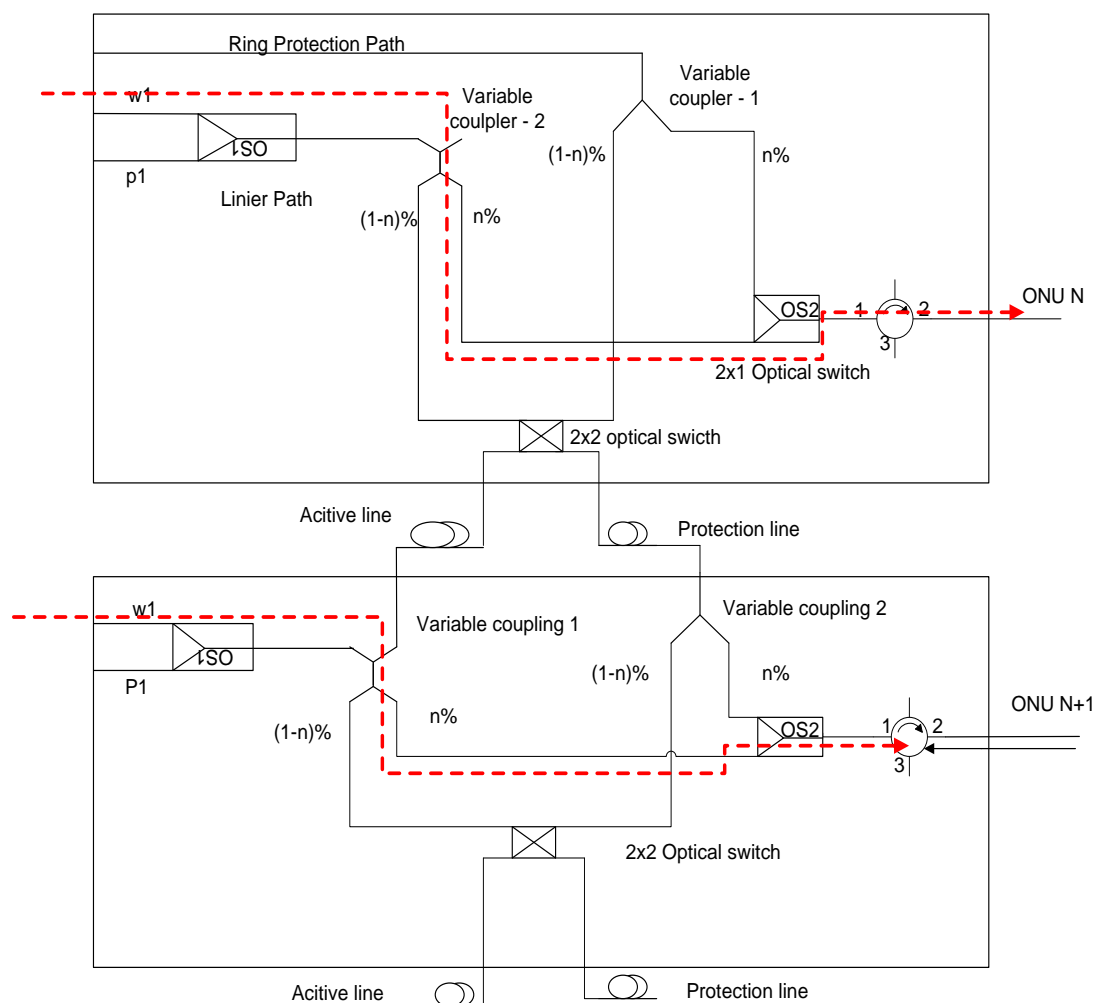

**Figure 2.** Optical signal flow in normal condition without any damage to the linear channel

### 2.2. First-fault condition (linear protection)

First of fault condition is categorized when the optical signalling is switched into the protection line while the active line broken [17, 18]. Figure 3 shows the dotted line that represented optical signal taken into receiver optical node on this protection circuit.

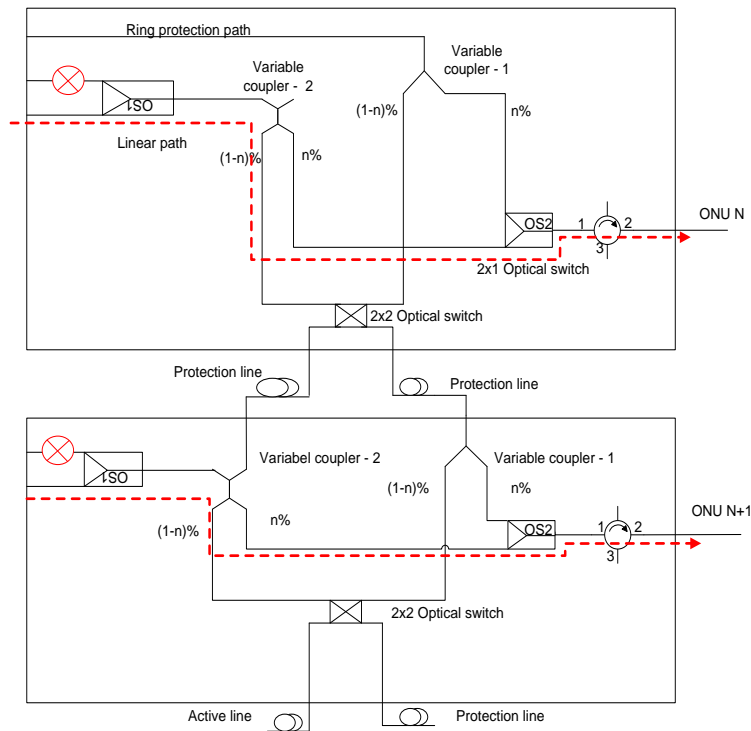

**Figure 3.** First stage of failure condition is active when protection line is applied for bring the information signal.

2. 3. *Second-fault condition (ring protection)*

The second stage of the fault condition occurs where the channel activated and the protection line broken, then protection line on the ring circuit will be activated [19]. Figure 4 shows the ring line is activated to bring optical signal into the receiver which two-signal type will function as a Dropped-Signal and Transmitted-Signal to next optical node.

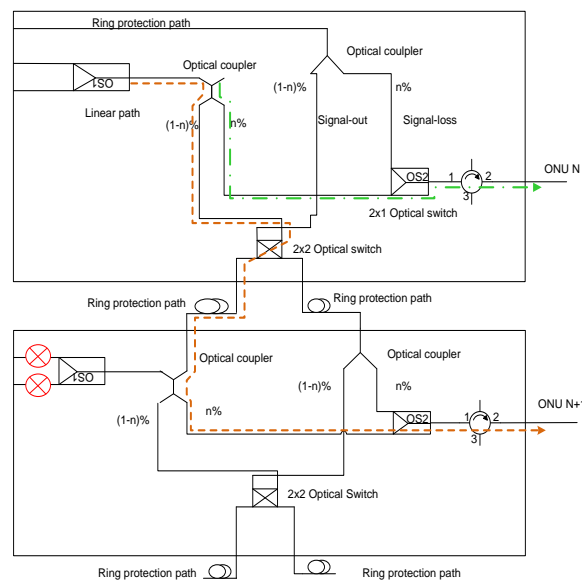

**Figure 4.** The situations when both channels on a linear circuit are destroyed, then the ring protection channel will be activated.

#### 2. 4. Third-fault condition (ring protection)

Figure 5 shows the third fault condition will active when the ring line broke and both of the line on the linier circuit is off the next series [19]. The Transmitted-Signal from the optical node is switched into the protection line and go into the optical coupler and accepted by the receiver.

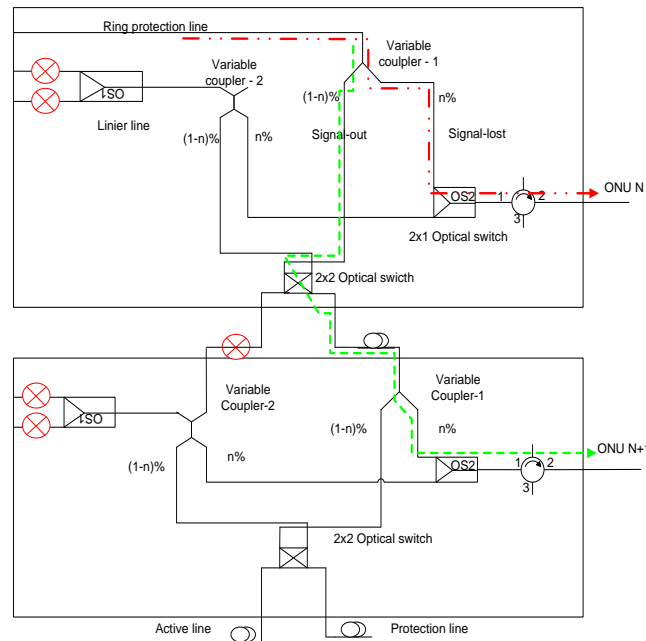

**Figure 5.** Ring protection line is used as the alternative channel if third condition is occurred

### 3. Calculation of channel dissipation at CAPU-RING optical node

Calculation analysis in this section aims to quantify the dissipation channel provided by the architecture of this channel protection system [15, 17]. Calculation of dissipation channel is important to know the channel dissipation budget based on the proposed circuit architecture. In this section a calculation of dissipation channel for 1490 nm wavelength for CAPU-RING 1 the first optical node and n-optical node. Calculation of power dissipation channel is divided into two specific channel that consists of a channel through a series of channels through a series of linear and ring.

Optical coupler is a device that can divide the optical signal (fiber) from one fiber to another by following the particular percentage ratio. In addition, the optical coupler can also combine optical signals from two or more lines in to a single fiber.

#### 3. 1. Linear protection scheme.

Based on the design of linear protection, optical signals can be sent directly to the ONU (Optical Network Unit) through the optical fiber (Single Mode Fiber, SMF), Optical Splitter, Optical switch, Optical Coupler, and finally optical circulator. There are two optical signal paths for signal direction that decreased (1490 nm and 1550 nm) in the linear path that consisting of the signal loss and the signal out components as shown in figure 1.2. Both of linear line and ring line using the fiber length of 15 km (cumulative distance).

#### Dropped – signal line

$$\begin{aligned}
 &= 15 \text{ Km (optical fiber)} + 1 \text{ unit (optical splitter)} \\
 &+ 3 \text{ unit(optical switch)} + 1 \text{ unit(optical coupler)} \\
 &+ 1 \text{ unit(optical circulator)}
 \end{aligned} \tag{1}$$

$$\begin{aligned}
&= \left(15 \text{ Km} \times 0.25 \frac{\text{dB}}{\text{Km}}\right) + (1 \times 8 \text{ dB}) + (3 \times 1.2 \text{ dB}) + (1 \times 1 \text{ dB}) + (1 \times 1 \text{ dB}) \\
&= 17.35 \text{ dB}
\end{aligned}$$

$$\begin{aligned}
&1 - \text{optical node of transmitted signal line} \\
&= 3 \text{ unit}(\text{optical swicth}) + 1 \text{ unit}(\text{optical coupler}) \\
&= (3 \times 1.2 \text{ dB}) + (1 \times 1 \text{ dB}) \\
&= 4.6 \text{ dB}
\end{aligned} \tag{2}$$

$$\begin{aligned}
&\text{Transmitted Signal path of optical node} - 1 \\
&= 15 \text{ Km}(\text{optical fiber}) + 1 \text{ unit}(\text{optical splitter}) \\
&\quad + (1 \times \text{optical node of signal line out}) \\
&= \left(15 \text{ Km} \times 0.25 \frac{\text{dB}}{\text{Km}}\right) + (1 \times 8 \text{ dB}) + (1 \times 4.6 \text{ dB}) \\
&= 16.35 \text{ dB}
\end{aligned} \tag{3}$$

$$\begin{aligned}
&\text{Transmitted Signal path of optical node} - 5 \\
&= 15 \text{ Km}(\text{optical fiber}) + 1 \text{ unit}(\text{optical splitter}) \\
&\quad + (5 \times \text{optical node of signal line out}) \\
&= \left(15 \text{ Km} \times 0.25 \frac{\text{dB}}{\text{Km}}\right) + (1 \times 8 \text{ dB}) + (5 \times 4.6 \text{ dB}) \\
&= 34.75 \text{ dB}
\end{aligned} \tag{4}$$

### 3. 2. Ring protection scheme.

Fault lines in the second and third stages involve the activation of the path of a ring network. Thus, the rings protection path can be used as alternative routes to bring optical signals to the ONU. Path analysis of the ring is stressed as a mechanism for protection of optical nodes. In away of the ring network, there are signal loss and the signal out components. The calculation of dissipation channels areas follows:

$$\begin{aligned}
&1 - \text{optical node of dropped} - \text{signal line} \\
&= 1 \text{ unit}(\text{optical coupler}) + 1 \text{ unit}(\text{optical swicth}) \\
&\quad + 1 \text{ unit}(\text{optical circulator}) \\
&= (1 \times 1 \text{ dB}) + (1 \times 1.2 \text{ dB}) + (1 \times 1 \text{ dB}) \\
&= 3.2 \text{ dB}
\end{aligned} \tag{5}$$

$$\begin{aligned}
&\text{Dropped} - \text{signal path of optical node} - 1 \\
&= 15 \text{ Km}(\text{optical fiber}) + (1 \times \text{optical node of signal lossline}) \\
&= \left(15 \text{ Km} \times 0.25 \frac{\text{dB}}{\text{Km}}\right) + (1 \times 3.2 \text{ dB}) \\
&= 6.95 \text{ dB}
\end{aligned} \tag{6}$$

$$\begin{aligned}
&\text{Dropped} - \text{signal path of optical node} - 5 \\
&= 15 \text{ Km}(\text{optical fiber}) + 1 \text{ unit}(\text{optical splitter}) \\
&\quad + (5 \times \text{optical node of signal loss line}) \\
&= \left(15 \text{ Km} \times 0.25 \frac{\text{dB}}{\text{Km}}\right) + (5 \times 3.2 \text{ dB}) \\
&= 19.75 \text{ dB}
\end{aligned} \tag{7}$$

1 – optical node of Dropped – signal out

$$\begin{aligned} &= 1 \text{ unit}(\text{optical swith}) + 1 \text{ unit}(\text{optical coupler}) \\ &= (1 \times 1.2 \text{ dB}) + (1 \times 1 \text{ dB}) \\ &= 2.2 \text{ dB} \end{aligned} \quad (8)$$

Dropped – signal path of optical node – 1

$$\begin{aligned} &= 15 \text{ Km}(\text{optical fiber}) \\ &\quad + (1 \times \text{optical node of signal line out}) \\ &= \left(15 \text{ Km} \times 0.25 \frac{\text{dB}}{\text{Km}}\right) + (1 \times 2.2 \text{ dB}) \\ &= 5.95 \text{ dB} \end{aligned} \quad (9)$$

Dropped – signal path of optical node – 5

$$\begin{aligned} &= 15 \text{ Km}(\text{optical fiber}) + \\ &\quad (5 \times \text{optical node of signal line out}) \\ &= \left(15 \text{ Km} \times 0.25 \frac{\text{dB}}{\text{Km}}\right) + (5 \times 2.2 \text{ dB}) \\ &= 14.75 \text{ dB} \end{aligned} \quad (10)$$

#### 4. Simulation and research

Network design is applied in scattered settlements of the clients with the linear combination of protection schemes and ring protection schemes [15, 17]. In addition, simulations are carried out to study the effectiveness of the security network architecture so that it can be used to expand and meet the correct specifications. This simulation aims to evaluate the effects of various parameters on the output power and BER performance on each node in the proposed network. Simulation of the entire range of coverage of this type was carried out on two types of protection. Simulations of protection of the network design of linear and ring protection carried out separately. Thus, the results of the simulation can be performed easily and the performance of the network coverage can be seen.

The main fiber distance is fixed at 15 km for the entire length of the optical fiber in the network protection. However, the distance between the ONU not specified. Proposal for a ring network involves five the number of ONU and the coupler is a variable optical coupler where it can be adjusted from 0% to100%. The data rate used to be way down in accordance with the EPON network protocol 1.25 GPS.

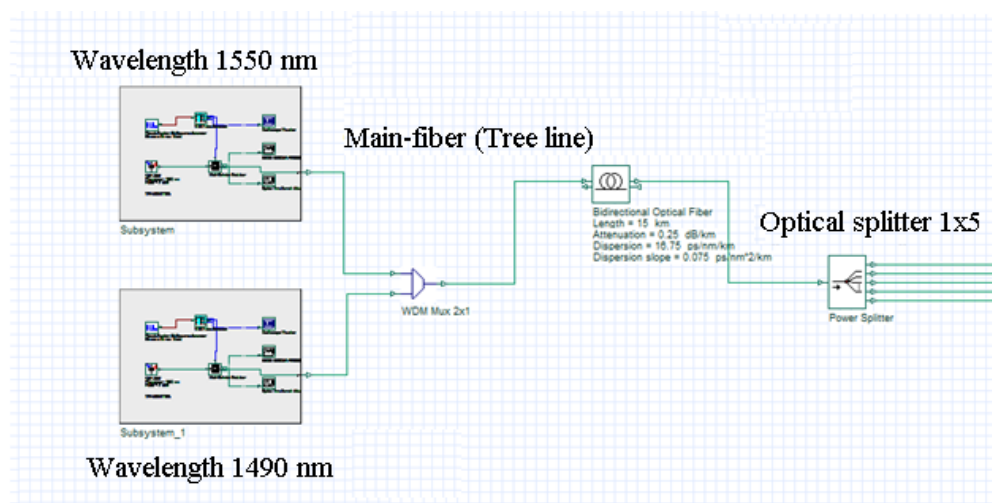

Figure 6. Design of feeder part for linear path



Figure 6 shows the design for the feeder of the linear network (main). 1550 nm and 1490 nm will be multiplexed by the range of protection network. Figure 7 shows the design for the network loss when a signal from the feeder to the five recipients will be divorced and then through the optical nodes. Figure 8 shows the components of the optical nodes that carry the signal to a linear path. For a ring network simulation platform is, Figure 9 shows the signal path for the entire ring network that contains five optical nodes connected together. Figure 10 shows the components through which the optical signal in an optical network node ring. Table 1 provides the parameters for the components - components that are used for the overall network security.

**Table 1.** Dissipation component parameters that used in the simulation

Devices	Dissipation according to the theoretical value of the product (dB)		
	1550 nm	1490 nm	1310 nm
15 km Optical Fiber (SMF-28)	0.20 dB/km	0.25 dB/km	0.35 dB/km
Optical Splitter 1x5	4.0	5.0	7.0
Optical Splitter 1x5	8.0	8.0	8.0
Optical Coupler	1.0	1.0	1.0
Optical Circulator	1.0	1.0	1.0
Optical Switch (1x2 and 2x2)	1.2	1.2	1.2
(de) Multiplexing	0.5	0.5	0.5

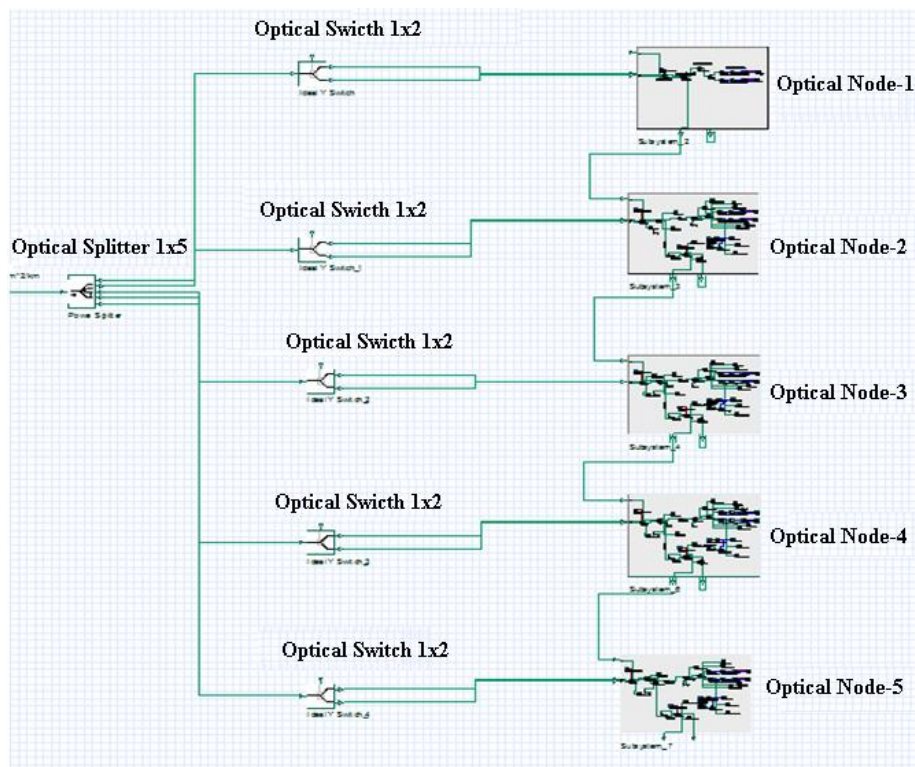

**Figure 7.** Design of loss part for linear path.

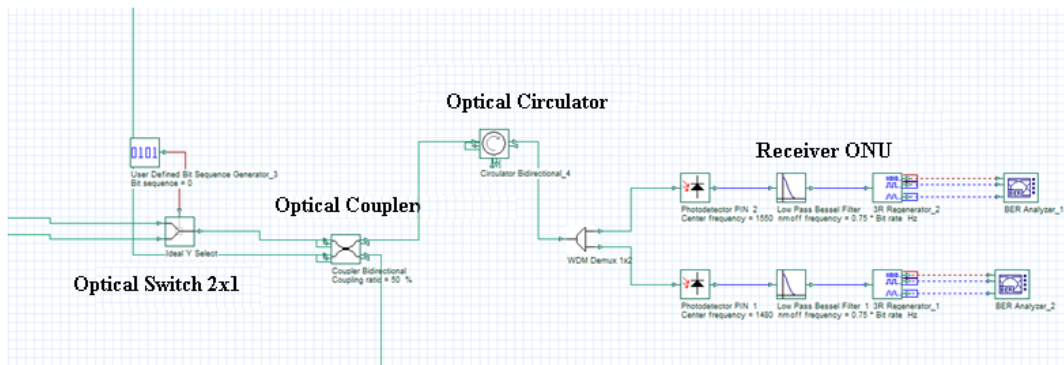

**Figure 8.** Optical node components to access the ring path.

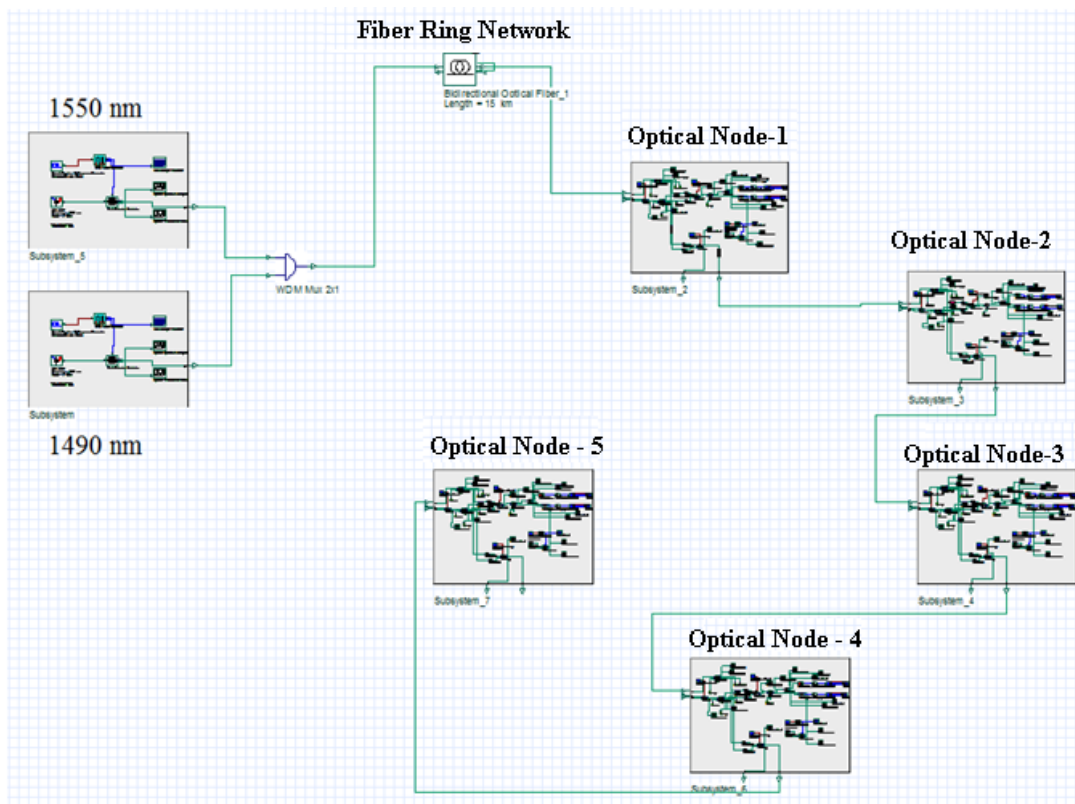

**Figure 9.** Overall of ring network with five optical node that is used.

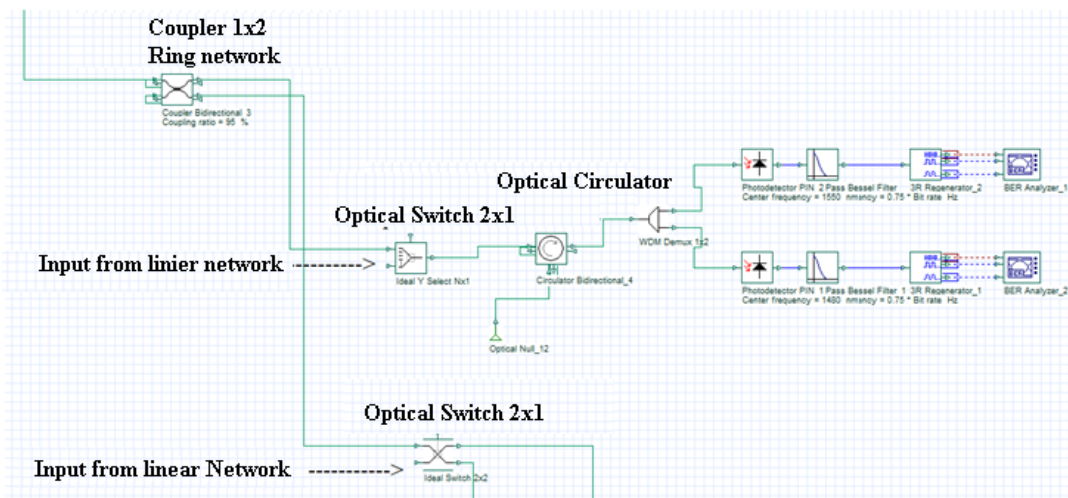

**Figure 10.** Optical node for signal route decline from ring network.

### 5. Node to node simulation analysis

Network protection scheme is a combination between the linear protection and the ring protection [15, 17]. Simulation analysis conducted for the node to node is divided into two main parts, namely a linear protection schemes and ring protection schemes. Each part of the protection scheme will investigate and get the power output of each node in the normal state (without damage), the maximum distance that can be achieved per each different protection schemes with the sensitivity and the maximum number of nodes that are -25 dBm, -30 dBm, -32 dBm and -35 dBm.

#### 5.1. The output power of each node at linear protection schemes

Linier protection path will enter into the optical coupler and it will be divided into two signals of the Transmitted-Signal and the Dropped-Signal. For the analysis of this issue, the first optical coupler is adjusted to a ratio of 50%: 50%. 50% as Dropped-Signal and 50% as Transmitted-Signal will be combined with a new signal from the next optical node. After seeing the performance of the output power of each optical node, the ratio of the optical coupler is varied to obtain optimum power output for each receiver at the optical node. Adjusted Transmitted-Signal goes to the (1-n) % and Dropped-Signal n%.

The design of linear protection, signals through the on-line coverage will not be linear decline upon it through then exit optical node until the end. It is caused by the optical signal power to be donated to the each node as the input power that is transmitted to the OLT (Main network) and it will be divorced by Optical Splitter for entering each optical node. In contrast to the ring network, the power output by each node is expected to shrink by following the optical node position.

Figure 11 shows the power output of the two wavelengths (1550 nm and 1490 nm) respectively to the Transmitted-Signal and the Dropped-Signal when the coupling ratio was adjusted to 50%:50%. Lower output power for the signal loss is the first node of -31.228 dBm (1550 nm) and -31.978 dBm (1490 nm). This may be due on the first node that does not have the power combination of the optical coupler of the previous node and making it the lowest power than other optical node. The lower Transmitted-Signal is the optical node to -29.593 (1550nm) and -30.343 dBm (1490nm). From the output power, the receiver sensitivity of -32 dBm can be carried out to linear protection scheme when the optical coupler is adjusted to 50%:50% for the Transmitted-Signal and the Dropped-Signal.

Subsequently, the percentage of random couplings is adjusted to obtain the lowest power output and the same for each optical node. Thus, the adjusted percentage is shown in Figure 12 where the ratio of the five-optical node will be adjustable individually. Figure 13 shows the results when the ratio of the output coupler is varied as shown in Figure 12. The highest power obtained at node-5 is -26.568 dBm (Dropped-Signal 1490 nm) and the lowest power at node-2 is -30.847 dBm (Dropped-Signal 1490 nm) where the highest Transmitted-Signal goes to the optical node-2 (the Transmitted-

Signal 1490 nm) and the highest Transmitted-Signal goes to the first optical node amount -34.656 dBm (1490 nm Transmitted-Signal). From the output of Dropped-Signal, the sensitivity can be reduced to -31 dBm. So by adjusting the ratio of the coupling is amount of 1 dBm, therefore sensitivity can be reduced.

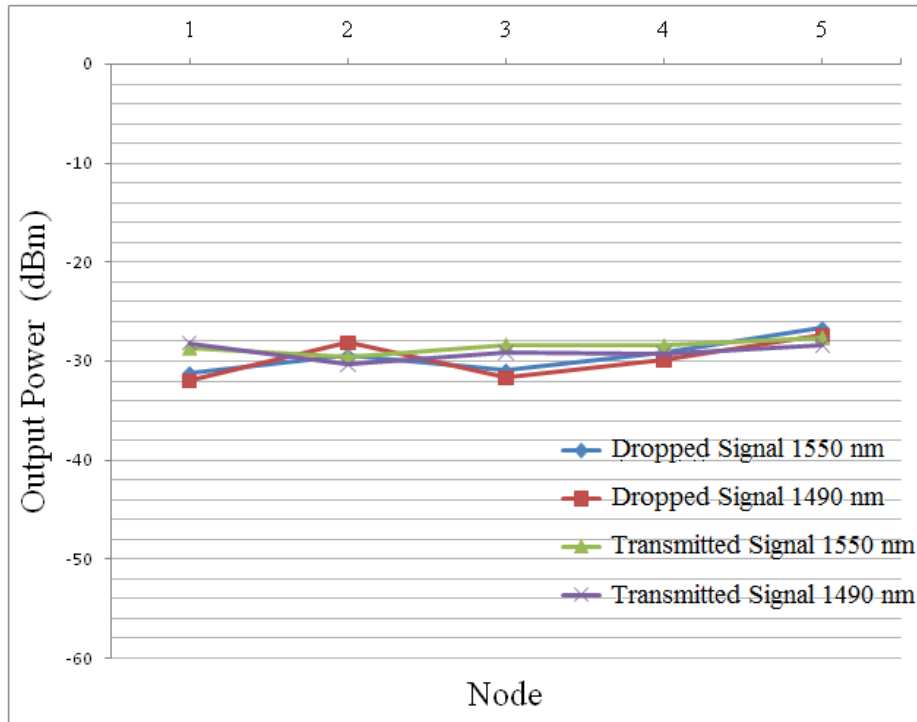

**Figure 11.** Output power of five optical node for the Transmitted-Signal and Dropped-Signal (1550 nm and 1490 nm) if coupling ratio is adjusted by 50%:50%.

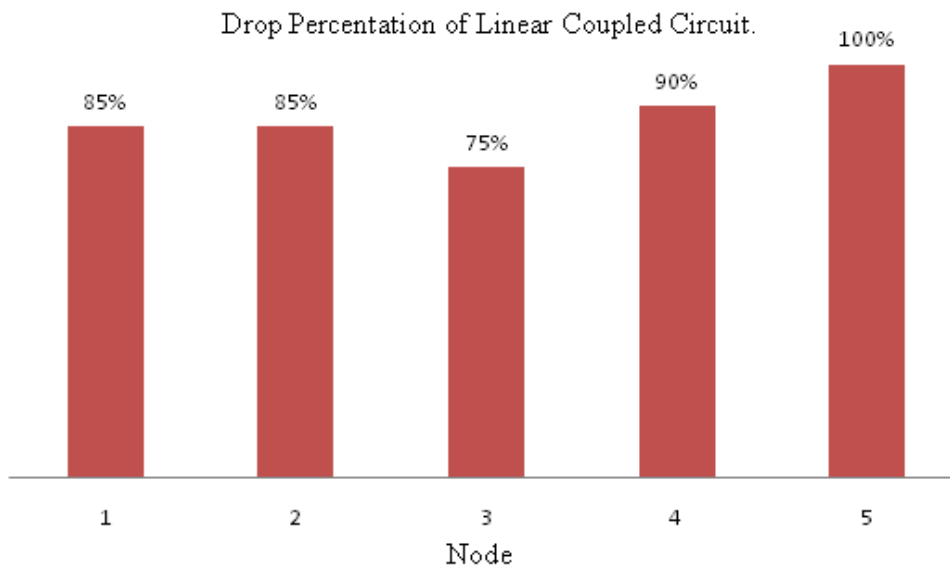

**Figure 12.** Percent of coupling ratio that is aligned by linier protection path

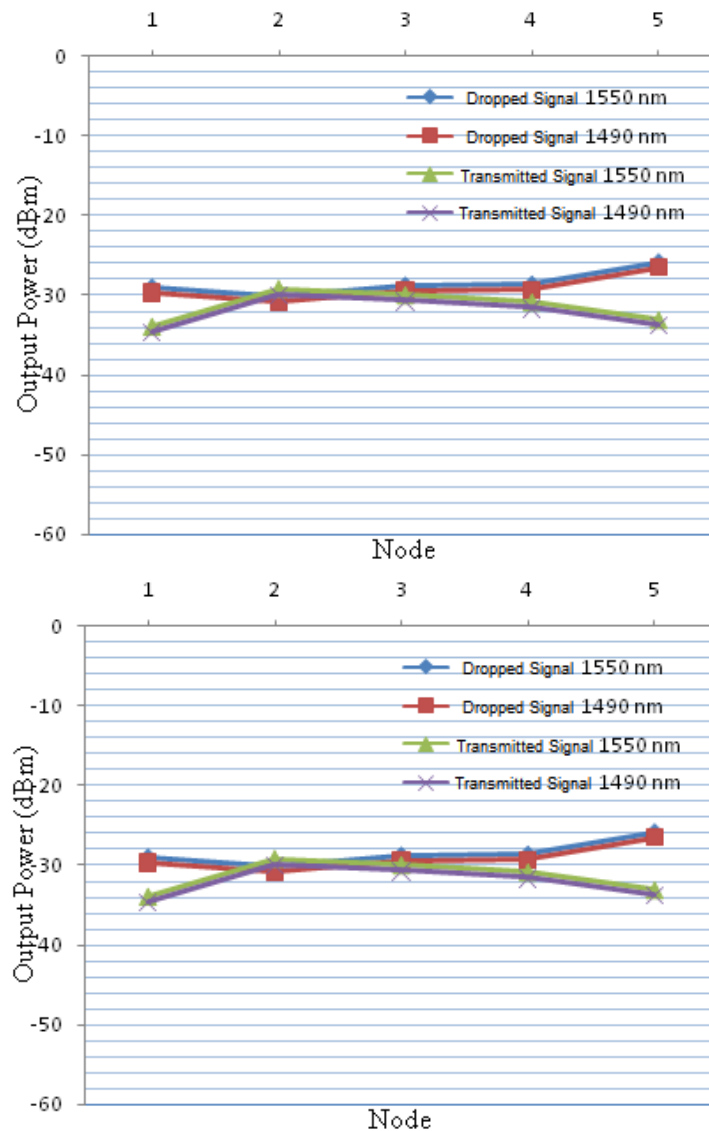

**Figure 13.** The output power of five optical nodes

### 5. 2. The output power of each node at ring protection schemes.

Signals through linear protection path will go in to the optical coupler and it will also be divided into the Transmitted-Signal and the Dropped-Signal. For ring protection schemes, the signal will be decreased when overrun the optical nodes. Thus, a study on the distribution of power from the coupler was run to obtain optimum power output. Signals through the coupler is adjusted according to Dropped-Signal ( $n\%$ ) and the Transmitted-Signal ( $1-n\%$ ).

a.  $(n, 1-n)$  where  $n$  is  $5\%$

In the beginning this power division analysis prescribing at  $(n, 1-n)$  with  $n$  is  $5\%$ . Therefore, signal loss is  $5\%$  from total power. Figure 14 shows output power per optical node for signal output ( $1490\text{ nm}$  and  $1550\text{ nm}$ ) and Dropped-Signal ( $1490\text{ nm}$  and  $1550\text{ nm}$ ). To be expected, lowest power for Dropped-Signal found in last optical node namely  $-32.53\text{ dBm}$  ( $1550\text{ nm}$ ) and  $-33.28\text{ dBm}$  ( $1490\text{ nm}$ ). Output powers for both kinds signal descend by linier when beyond number optical node. These cases happen when signal that go through the optical node would be experiencing power depreciation.

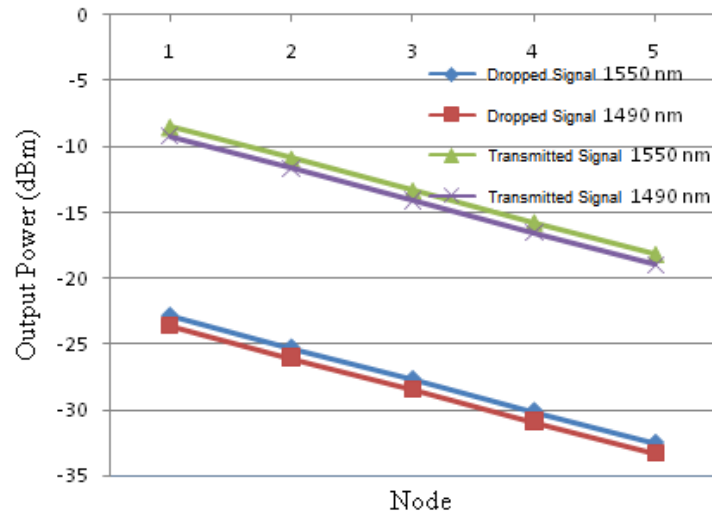

**Figure 14.** Output power to 5 optical node for Transmitted-Signal and Dropped-Signal (1550 nm and 1490 nm) when coupler ratio adjusted to 95%:5% (95% Transmitted-Signal and 5% Dropped-Signal).

b. (n,1-n) where n is 10%.

Ratio of power division (n,1-n) where n as Dropped-Signal and Transmitted-Signal as much as 10% and 90% respectively. This power division ratio empowering a bit bigger to receiver. There are many primordial nodes that were not appropriate as earliest node and they do not experience power depreciation that so bad. Figure 15 shows output power per optical node for Transmitted-Signal (1490 nm and 1550 nm) and Dropped-Signal (1490nm and 1550nm) that descends by linier when across optical node in the optical network. The output power node-1 to node-5 for wavelength 1550nm are -19.829 dBm, -22.487 dBm, -25.144 dBm, -27.802 dBm and -30.458 dBm respectively. The wide dynamic range is needed to get a good signal.

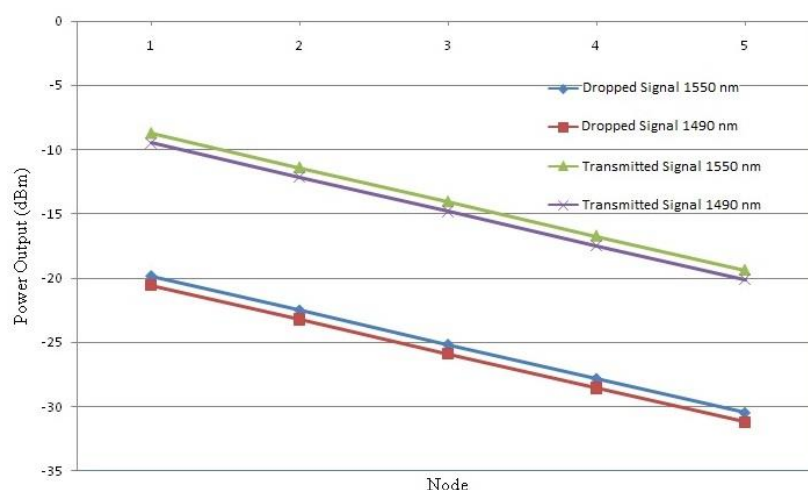

**Figure 15.** Five optical nodes of output power for the optical transmitted signal and the dropped signal, when the ratio of the coupler is adjusted to 90%: 10%.

c. (n, 1-n) where n is the changing value (1% -100%).

Simulation of the coupling ratio is adjusted by signal changing has been conducted. It seeks to obtain optimum power output to reduce the depreciation of the main applicable to the last optical node. By setting the ratio of these readings, there are couplings in the same ratio to all optical nodes. This is not just looking at a different position in which optical node of the ring structure also contributed to the varying loss and reduces the number of ONU (Yeh&Chi, 2008). Thus, the ratio for each coupler is changed at random so that the output power obtained for optimum optical nodes.

Optimization to obtain the coupling ratio on the power set can be done with the extraction of simulation parameters method. These parameters using optimization method in which the ratio of the optical coupler is extracted to obtain the specific power output. Optimization will find the ratio of the optical coupler to achieve a power output of the power meter as required. As the number of optical nodes exceeds 1, the optimization of various parameters has been carried out. It is found that the coupling ratio of the optical nodes will be varied to obtain the specific power output by using OPTYSYSTEM.

Figure 16 shows reading ratio (percentage) in optical-coupler when output power in -23dBm by using parameter extraction method with simulation result is -23dBm. Output power is chosen as output power that most maximum achievable to supply power at all optical node. If fixed power is less than -23dBm, so power was not enough to supply all optical node as signal, so the optical node have to be divided in each nodes that crossed him. Therefore, based on adjustment that carried out product power average as much as -23dBm to five optical nodes that inserted in the network

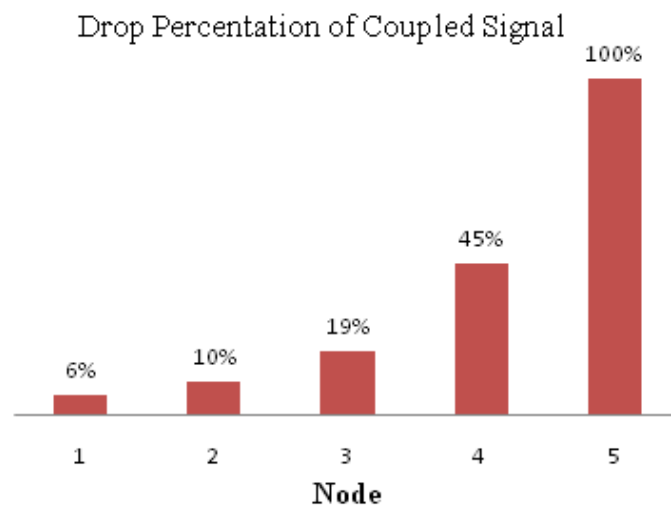

**Figure 16.** Percentage of optical-coupler ratio for all the optical nodes.

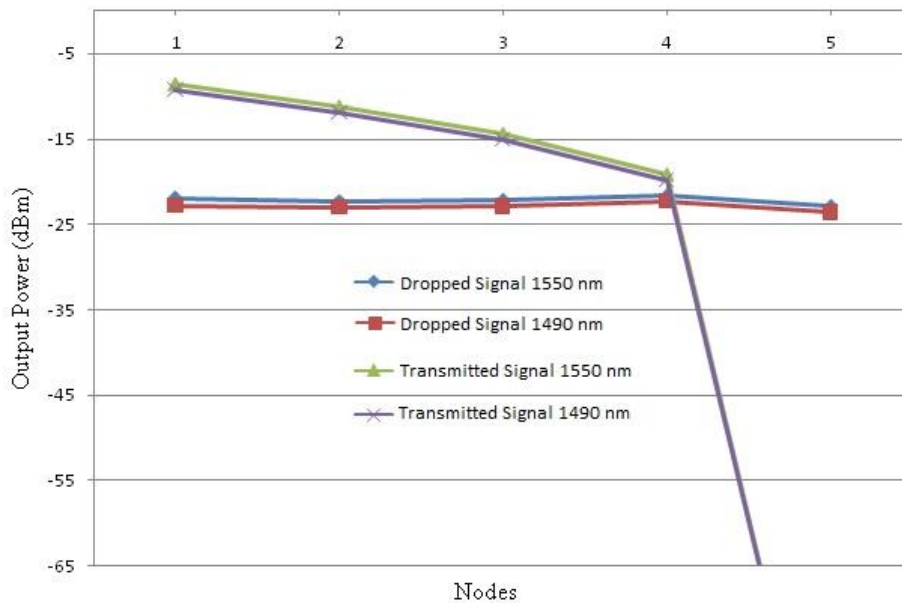

**Figure 17.** Power output to 5-optical node as a transmitted signal and a dropped signal (1550nm and 1490nm) when coupling ratio adjusted to varied ratio.

Figure 17 shows output power at every optical node for Dropped-Signal and Transmitted-Signal. Power product achieved for dropped signal when optical coupler adjusted to get optimum power output per optical node. The transmitted signal at last node on the other hand adjusted to -100 dBm due to no more optical node that in turn to carry the signal.

## 6. Discussion

Characterization and study of protection schemes in the placement of order and scattered settlements had been conducted through simulation analysis [16, 17, 19]. The characterization was carried out taking into account the performance and design of the accessibility of the physical layer only. It was found that there were clear differences in terms of dynamic range all the damage, the maximum distance that can be achieved and also the recovery of each design is constructed.

Table 2 shows the comparison of each design of the accessibility of the protection scheme. For proper placement of the protection scheme, the recovery of damages up to the level-3 to the highest level of protection scheme designs from scattered settlements. However, to support the protection scheme until the third recovery phase, the necessary dynamic range is also higher, up to 30.502 dBm for the case as shown (for the cumulative distance of 15km). In addition, the maximum distance that can be achieved at the third level of damage is on the wane for architecture in the placement of proper protection scheme. Accessibility in terms of maximum distance on scattered settlements showed similar values in each case, damage was not different signal path for the route path protection ring and linear (hybrid protection) than the ratio of the optical coupler is adjusted at each node so that the optical output power is same at each node.



**Table 2:** Comparative performance of the repair, dynamic range, and maximum range for each type of recovery scheme in the network.

Characterisation	Regular placement*	Scattered placement **	
	Protection <i>Linear</i>	Hibrid-Protection	Ring-protection
Repairing Stages :	Stage-3	Stage -3	Stage-1
Dynamic range:			
i) Normal condition	23.80 dBm	28.42 dBm	27.42 dBm
ii) Stage-1 failure	26.05 dBm	28.42 dBm	27.42 dBm
iii) Stage-2 failure	28.10 dBm	29.58 dBm	-
iv) Stage-3 failure	30.50 dBm	29.58 dBm	-
Maximum Distance:			
i) Normal Condition	60.50 km	40.80 km	50.60 km
ii) Stage-1 failure	51.00 km	40.80 km	50.60 km
iii) Stage-2 failure	43.00 km	40.50 km	-
iv) Stage-3 failure	33.80 km	40.50 km	-

Proper placement\*: results obtained for the linear network and the sensitivity of -35 dBm at a data rate. 25 Gbps (down path) is taken to the wavelength of 1550 nm. The average readings from the simulation results taken at eight ONU at a distance of 15 km. Reading dynamic range and the maximum distance is achieved in accordance with the results of the simulation.

Placement of Dispersed \*\*: The results obtained for a ring network for the protection scheme and the hybrid ring and the sensitivity of -35 dBm at a data rate. 25 Gbps (halaan down) is taken to the wavelength of 1550 nm. Average of eight readings taken at ONU in the optical node with eight total distance 15 km. Reading dynamic range and the maximum distance is achieved in accordance with the results of the simulation.

## 7. Conclusion

Among the results discussed in the development of protection schemes to be applied in the proper placement is associated with a dynamic range of each of the damage, range and accessibility of the growing number of consumers and their impact on dynamic range and sensitivity. In addition to the restoration scheme can carry up to 3 the extent of damage are also implications for the network with the highest level of recovery of the resulting dynamic range is also high time to do the recovery is also increased.

## Acknowledgments

This project had been carried out in the computer and network security research group laboratory under the department of electrical, electronic and system engineering, Universiti Kebangsaan Malaysia (UKM), Selangor, Malaysia and Department of Electrical Engineering, Universitas Muhammadiyah Prof. Dr. HAMKA, Jakarta, Indonesia. All authors and co-authors are contributed in this project.

## References

- [1] Yeh C H and Chi S 2008 Self-protection against fiber fault for ring-based power-splitting passive optical networks *Optical Engineering* vol **47** no 2 pp 020501, DOI: 10.1117/1.2841702.
- [2] Chuan N B, Ab-Rahman M S and Premadi A 2011 Installation and field testing of video delivery system *Asian Journal of Applied Sciences* vol **4** no 4 pp 423-30 DOI: 10.3923/ajaps.2011.423.430.
- [3] Ab-Rahman M S, Chuan N B and Jumari K 2009 Engineering a network management system for FTTH access network *Journal of Applied Sciences* vol **9** no 13 pp 2390-98 DOI: 10.3923/jas.2009.2390.2398
- [4] Prat J 2008 Research towards unlimited bandwidth access in *Next-Generation FTTH Passive Optical Networks J Prat* Ed 1<sup>st</sup> ed Netherlands: Springer Science & Business Media p 188,

ISBN: 978-90-481-7889-6.

- [5] Ab-Rahman M S, Chuan N B, Kasimin R and Jumari K 2010 Engineering installation works on FTTH-PON laboratory test bed: Case study *Journal of Applied Sciences* vol 10 no 1 pp 29-36 DOI: 10.3923/jas.2010.29.36.
- [6] Chuan N B, Ab-Rahman M S, Premadi A and Jumari K 2010 Optical fault monitoring method in 8-branched PON-based i-FTTH *Research Journal of Information Technology* vol 2 no 4 pp 215-27 DOI: 10.3923/rjit.2010.215.227.
- [7] J. Paul E G 2006 *Fiber to the Home: The New Empowerment* vol 4 New Jersey: John Wiley & Sons ISBN: 9780471755630.
- [8] Jirachariyakool R, Sraium N and Lerkvaranyu S 2017 Design and implement of GPON-FTTH network for residential condominium in *14th International Joint Conference on Computer Science and Software Engineering (JCSSE)* Nakhon Si Thammarat Thailand 2017 pp 1-5 DOI: 10.1109/jcsse.2017.8025942.
- [9] Żotkiewicz M and Mycek M 2017 Reducing the costs of FTTH networks by optimized splitter and OLT card deployment *Journal of Optical Communications and Networking* vol 9 no 5 pp 412-22 DOI: 10.1364/jocn.9.000412.
- [10] Chuan N B, Ab-Rahman M S, Premadi A and Jumari K 2010 Optical power budget and cost analysis in PON-based i-FTTH *Research Journal of Information Technology* vol 2 no 3 pp. 215-27 DOI: 10.3923/rjit.2010.127.138.
- [11] Ab-Rahman M S, Azizan L A H, Aziz S A C and Jumari K 2011 The eye diagram analysis of restoration scheme in FTTH-PON *Journal of Applied Sciences* vol 11 no 5 pp 840-47 DOI: 10.3923/jas.2011.840.847.
- [12] Ab-Rahman M S, Ehsan A A and. Shaari S 2006 Survivability in FTTH PON access network using optical cross add and drop multiplexer switch *Journal of Optical Communications* vol 27 no 5 pp 263-69 DOI: 10.1515/joc.2006.27.5.263.
- [13] Ab-Rahman M S, Baharuddin A, Chuan N B, Aziz S A C and Hashim S 2009 Analysis of equipment failure & risk in fiber-to-the home customer access network & reduction techniques proposal *Australian Journal of Basic and Applied Sciences* vol 3 no 4 pp 3692-3702.
- [14] Ab-Rahman M S, Hassan S R, Aziz S A C and Jumari K 2009 Implementation of customer protection device (CPD) in FTTH EPON *International Journal of Computer Science and Network Security* vol 9 no 3 pp 125-9.
- [15] Aziz S A C, Ab-Rahman M S and Jumari K 2009 Automatic protection unit in application of restoration scheme for FTTH passive optical network in *International Conference on Computer Technology and Development (ICCTD)* Kota Kinabalu pp 256-9 DOI: 10.1109/icctd.2009.244.
- [16] Ab-Rahman M S, Hassan S R and Jumari K 2009 Customer access protection unit (CAPU) performing auto-restoration in line with access control system (ACS) for FTTH customer's network in *International Conference on Space Science and Communication 2009* pp 74-77 DOI: 10.1109/iconspace.2009.5352665.
- [17] Aziz S A C, Ab-Rahman M S and Jumari K. 2009 Customer access protection unit for survivable FTTH network," in *International Conference on Space Science and Communication* Port Dickson Neg Sembilan Malaysia pp 71-73 DOI: 10.1109/iconspace.2009.5352668.
- [18] Premadi A, Ab-Rahman M S, Aziz S A C and Jumari K 2009 Acces control System: a cost effective protection scheme for fiber fault identification in *International Conference on Signal Acquisition and Processing (ICSAP)* The MINES Reseort city Seri Kembangan Selangor 2009 pp 57 – 60.
- [19] Aziz S A C, Ab-Rahman M S and Jumari K 2010 Self restorations through multi line drop mechanism in intelligent FTTH in *Regional Engineering Postgraduate Conference (EPC)* Hotel Equatorial Bangi Malaysia.